



ICE ENERGY®

INTELLIGENT STORAGE AT WORK.™

Ice Bear® 30 Unit

Installation & Maintenance Guide

for models:
IB30A-521
IB30A-523
IB30A-543

serial numbers:
through #xxxx10140

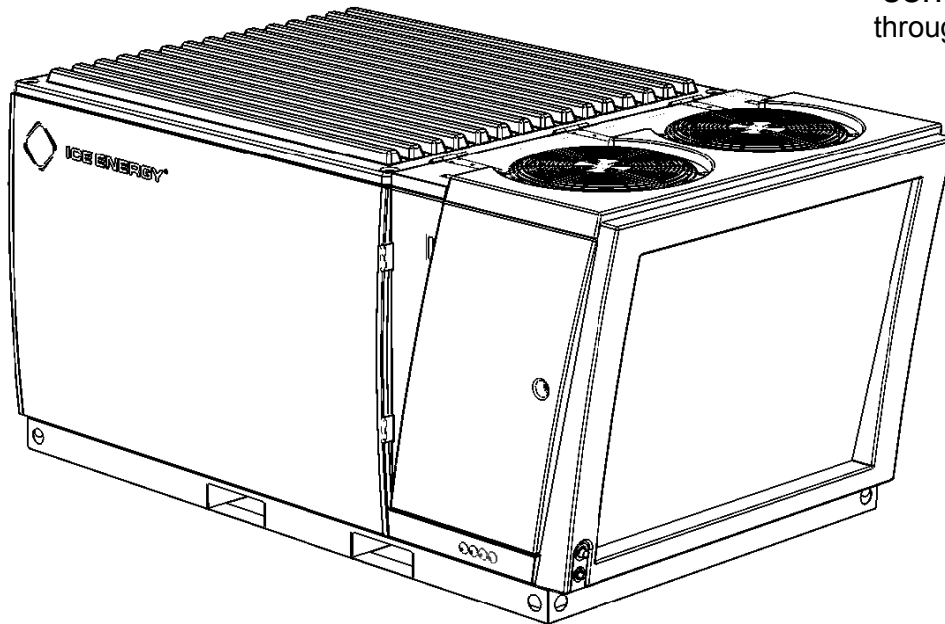

Phone: (877) 542-3232
Fax: (970) 545-3634
Email: productservices@ice-energy.com
www.ice-energy.com

Industry Recognition



CALIFORNIA TITLE 24 – 2005
Optional Compliance Measure
Energy Efficiency Standards, 2006



Consortium of US Federal Labs
WORLD'S BEST TECHNOLOGIES,
Gold Award, 2004



FLEX YOUR POWER AWARD
for Permanent Peak Power Shifting, 2007



TOP-10 GREEN BUILDING
Product of 2005
BuildingGreen Magazine



ENERGY VENTURE FAIR
Most Promising Company Award,
2003, 2004, 2005



ASHRAE / ARI
AHR Expo
Product of the Year, 2004
Energy Management
Green Building Innovation
Award 2009



NORTHERN COLORADO
BUSINESS REPORT
Innovative Business Award, 2005

Copyright, Notices, and Trademarks

© Ice Energy, Inc., 2010. All Rights Reserved.

No reproduction/distribution without permission.

While this information is presented in good faith and believed to be accurate, Ice Energy disclaims the implied warranties of merchantability and fitness for a particular purpose and makes no express warranties except as may be stated in its written agreement with and for its customers.

In no event is Ice Energy liable to anyone for any indirect, special or consequential damages. The information and specifications in this document are subject to change without notice. Visit www.ice-energy.com to ensure that you have the latest version.

Ice Energy, Ice Bear and CoolData are registered trademarks and Ice-Ready and Ice-Coil are trademarks of Ice Energy, Inc. Other brand or product names are trademarks of their respective owners.

Table of Contents

| | |
|---|----|
| Introduction..... | 1 |
| Definitions of Terms..... | 1 |
| A Few of the Unique Installation & Startup Considerations | 2 |
| Ice Bear® 30 Unit Ratings by Ton-hour..... | 2 |
| About this Guide..... | 3 |
| Ice Bear® 30 Unit Components..... | 3 |
| Modes of Operation | 6 |
| CoolData® Controller..... | 8 |
| Features..... | 8 |
| Control Schematic | 9 |
| Control Configuration Example | 9 |
| Applications..... | 10 |
| Typical Applications..... | 10 |
| Sample Ice Bear® Unit Configurations..... | 10 |
| Pre-installation..... | 12 |
| General Precautions & Responsibilities | 12 |
| Required Tools/Accessories | 12 |
| Transporting the Ice Bear® Unit | 13 |
| Installation | 14 |
| Minimum Clearances..... | 14 |
| Ice Bear® 30 Unit Lifting Instructions..... | 16 |
| Mounting | 18 |
| Refrigerant Piping..... | 24 |
| Filling Ice Storage Tank | 29 |
| Electrical Connections..... | 31 |
| CoolData® Controller Connections..... | 34 |
| Controller Program and Configuration File..... | 35 |
| Post Installation..... | 35 |
| Installation Checklist | 35 |
| Monitoring..... | 36 |
| Service Switch | 36 |
| System Startup & Verification..... | 38 |
| Sequence of Operation..... | 38 |
| Pre-startup Safety Warnings | 40 |
| Pre-startup..... | 40 |
| Startup..... | 41 |
| CoolData® Controller LEDs | 42 |
| Software Verification | 43 |
| Maintenance..... | 44 |
| General Maintenance..... | 44 |
| Periodic Maintenance | 44 |
| Low Ambient Operation | 45 |
| Water Pump Cycling | 45 |
| Fan Cycling | 45 |
| Appendix A – Product Specifications..... | 46 |

List of Figures

| | |
|---|----|
| Figure 1 - Ice Bear [®] Unit Exterior Components | 3 |
| Figure 2 – Ice Bear [®] Unit Internal Components (Left Side)..... | 4 |
| Figure 3 – Ice Bear [®] Unit Internal Components (Right Side) | 5 |
| Figure 4 – Refrigerant Flow Schematic – Ice Make Mode | 6 |
| Figure 5 – Refrigerant Flow Schematic – Ice Cooling Mode | 7 |
| Figure 6 – CoolData [®] Controller | 8 |
| Figure 7 – Control Schematic | 9 |
| Figure 8 – Single Zone, Single-stage Thermostat with Economizer and Backup Condensing Unit..... | 9 |
| Figure 9 – Ice Bear [®] Unit (Parallel) with Ice-Ready [™] Rooftop Unit | 10 |
| Figure 10 – Redundant (Parallel) Split System..... | 11 |
| Figure 11 – Ice Bear [®] 30 Unit Forklift Slot Dimensions..... | 13 |
| Figure 12 – Minimum Clearances for Unit-mounted Service Disconnect..... | 14 |
| Figure 13 – Minimum Clearances for Units with Internal Service Disconnect Switch | 15 |
| Figure 14 – Ice Bear [®] 30 Unit Lifting Points | 16 |
| Figure 15 – Required Spreader Bar Configuration | 17 |
| Figure 16 – Typical Roof Mount Installation (Steel Support Structure)..... | 19 |
| Figure 17 – Typical Roof Mount Installation (Wooden Support Structure)..... | 20 |
| Figure 18 – Ice Bear [®] 30 Unit on Structural Curb with Cap | 21 |
| Figure 19 – Minimum Recommended Concrete Pad Dimensions | 22 |
| Figure 20 –Sample Precast Concrete Pad | 23 |
| Figure 21 – Valve Locations..... | 24 |
| Figure 22 – Refrigerant Piping Connection Points | 25 |
| Figure 23 – Valve Locations..... | 28 |
| Figure 24 – Ice Bear [®] Unit Water Fill Level | 29 |
| Figure 25 – Upper Link-Seal [®] | 30 |
| Figure 26 – Link-Seal Tightening Sequence..... | 30 |
| Figure 27 – Mounting Service Disconnect Box (Right Side) | 31 |
| Figure 28 – Mounting Service Disconnect Box (Left Side) | 32 |
| Figure 29 – Service Disconnect Switch | 32 |
| Figure 30 – CoolData [®] Controller Components | 34 |
| Figure 31 – Service Switch | 36 |
| Figure 32 – New Service Switch & Location | 37 |
| Figure 33 – Ice Bear [®] Unit Rear & Side Views..... | 46 |
| Figure 34 – Ice Bear [®] Unit Top View | 46 |
| Figure 35 – Ice Bear [®] 30 Unit Dry Center of Gravity (Left)..... | 47 |
| Figure 36 – Ice Bear [®] 30 Unit Dry Center of Gravity (Top) | 47 |
| Figure 37 – Ice Bear [®] 30 Unit Wet Center of Gravity (Left)..... | 48 |
| Figure 38 – Ice Bear [®] 30 Unit Wet Center of Gravity (Top)..... | 48 |

Introduction

The ICE BEAR[®] 30 unit is an off-the-shelf distributed energy storage system for use with direct expansion air conditioning units. The Ice Bear unit is designed to store energy at night and then shift the on-peak electrical energy of a condensing unit common to packaged rooftop, split, and mini-split systems. A typical application will shift the electrical energy consumed by a 5-ton scroll compressor and its associated condensing unit fans operating under full load conditions for 6 hours continuously. Electrically, the Ice Bear unit shifts approximately 30 kW-hours of energy to the off-peak, thus reducing the on-peak demand by about 6 kW for six hours.

The Ice Bear unit runs its integral condensing unit for about 10 hours continuously, during the coolest part of the night, to store energy in the form of ice (30 latent ton-hours). The control signal from the thermostat or building management system is received by the Ice Bear unit's CoolData[®] controller. Based on the time-of-day, or upon a command to shed electrical demand initiated by the utility, the controller determines if the Ice Bear hybrid condensing unit or the electrically operated condensing unit will operate. In the case of the Ice Bear unit, it pumps enough oil free R-410A refrigerant to an Ice-Coil evaporator to provide effective cooling for up to 5 tons of continuous load for six hours, using less than 300 watts of power. A unique and important design feature is the Ice Bear unit's cooling performance independent of outdoor ambient or rooftop temperature; in other words, it can be 75 °F or 140 °F and the Ice Bear unit and its associated Ice-Coil's cooling performance (5-ton rating) is unchanged.

Definitions of Terms

Base System: A refrigerant based, direct expansion (DX) air conditioning system, commonly referred to as a packaged rooftop unit, split system, or mini-split system. A typical base system includes a condensing unit, an evaporator, a blower, and controls.

Ice-Coil™ Kit: An Ice-Coil and ancillary equipment needed to convert a packaged rooftop unit into an Ice-Ready Rooftop Unit.

Ice-Coil™: A flooded evaporator coil provided by Ice Energy, or modified to Ice Energy's specifications. The Ice-Coil is dedicated to the Ice Bear unit and is sometimes referred to as a liquid overfeed evaporator coil.

Ice-Cooling: The process whereby the Ice Bear unit's stored ice cools the refrigerant used to provide cooling to a building space during peak energy hours (typically noon to 6pm).

Ice-Make: The nighttime process by which the Ice Bear unit converts its tank of water into a tank of ice to be used for cooling the next day during the peak energy hours (typically noon to 6pm).

Ice-Ready™ Rooftop Unit: A packaged rooftop unit modified to include an Ice-Coil.

Multi-Stage System: A packaged rooftop unit, typically greater than 5 tons, that includes multiple independent refrigeration circuits, for example a 10-ton unit with two 5-ton circuits.

Peak Shifting: Shifting electric load from the utility defined on-peak period to the off-peak period. On-Peak hours are typically noon through 6 pm.

Redundant Coil: The addition of an Ice-Coil to a packaged rooftop unit or split system.

Summer Mode: The CoolData[®] controller's programming is optimized to insure that stored cooling is available during peak energy hours.

Standard Circuit: A common DX refrigeration circuit that includes an evaporator coil, expansion device, and condensing unit.

Ton-hours: Capacity in tons times the number of hours (e.g., 5 tons for 6 hours = 30 ton-hours); an important design consideration for fixed capacity storage units such as the Ice Bear unit.

Winter Mode: The CoolData controller is programmed to extend the Ice Cooling hours to more fully utilize the stored cooling capacity of the unit.

A Few of the Unique Installation & Startup Considerations

- In addition to the Base System, an Ice-Coil must be used, which is typically a Redundant Coil.
 - A flooded evaporator coil is provided by Ice Energy, or modified to Ice Energy's specifications, or included as part of an Ice-Ready Rooftop Unit, whose sole purpose is to connect to the Ice Bear unit. Uniquely, an Ice-Coil does not use any type of expansion device (orifice, TXV, or EEV); hence the term liquid overfeed or flooded coil. A mixed phase of liquid and vaporized refrigerant may return to the Ice Bear unit.
- Length, sizing, and insulation of the refrigerant supply and return line sets.
 - The Ice Bear unit may be located on the ground or on the roof in close proximity to the Ice-Coil; there are distance and elevation limitations to consider. A unique feature of the Ice-Coil circuit is that it is charged with oil free R-410A refrigerant.
 - The liquid supply line from the Ice Bear unit to the Ice-Coil and the vapor return line from the Ice-Coil to the Ice Bear unit are uniquely sized to Ice Energy's design specifications. Both the liquid supply and the vapor return line sets must be insulated.
- When to fill with water and its associated weight
 - One of the last steps in the startup sequence is to fill the Ice Bear unit with about 450 gallons of tap water. When to fill the Ice Bear unit is important; filling too soon could cause significant and costly damage to the unit.
 - The filled weight of the Ice Bear unit is an important consideration for both ground mount and roof mount applications.
- Remote Monitoring and Control
 - The Ice Bear unit is centrally monitored and may be controlled remotely. To enable this feature, the unit must be connected to the Ice Energy Network Operations Center by a wired or by wireless data service (such as the Internet). Typically, a wireless (3G) data connection is installed and configured by Ice Energy. Provision may be required for an external antenna and/or an alternate service (Internet) connection in areas where coverage is inadequate.
- Heat Pumps
 - When applying an Ice Bear 30 unit to a heat pump, the Ice Bear unit must have a dedicated (redundant) Ice-Coil.
 - Additional control strategies vary based on RTU manufacturer.

Ice Bear[®] 30 Unit Ratings by Ton-hour

Importantly, the Ice Bear unit has a limited amount of cooling capacity and therefore proper consideration of the building's cooling load profile is a critical step and must not be overlooked. The Ice Bear unit should not be used as the only source of cooling for typical office building, restaurant, and retail designs.

- Storage capacity: 30 ton-hours at a peak load of 5 tons
 - 5 tons for 6 hours, or 4 tons for 7.5 hours, or 3 tons for 10 hours
- Instantaneous output capacity is unaffected by ambient temperature

About this Guide

This installation guide is intended to provide basic product information, specifications, and general guidelines to assist in the installation and startup of the Ice Bear unit by persons with factory training certification. This guide is not intended to provide comprehensive instructions nor replace factory training. Consult your Ice Energy representative for additional information.

Phone: (877) 542-3232 or (970) 545-3630, Fax: (970) 545-3634, www.ice-energy.com
 Email: productservices@ice-energy.com

NOTE: Read and understand this entire manual before beginning installation.

! WARNING

Before installing, modifying, or servicing the unit, the main electrical disconnect switch must be in the OFF position.

Ice Bear[®] 30 Unit Components

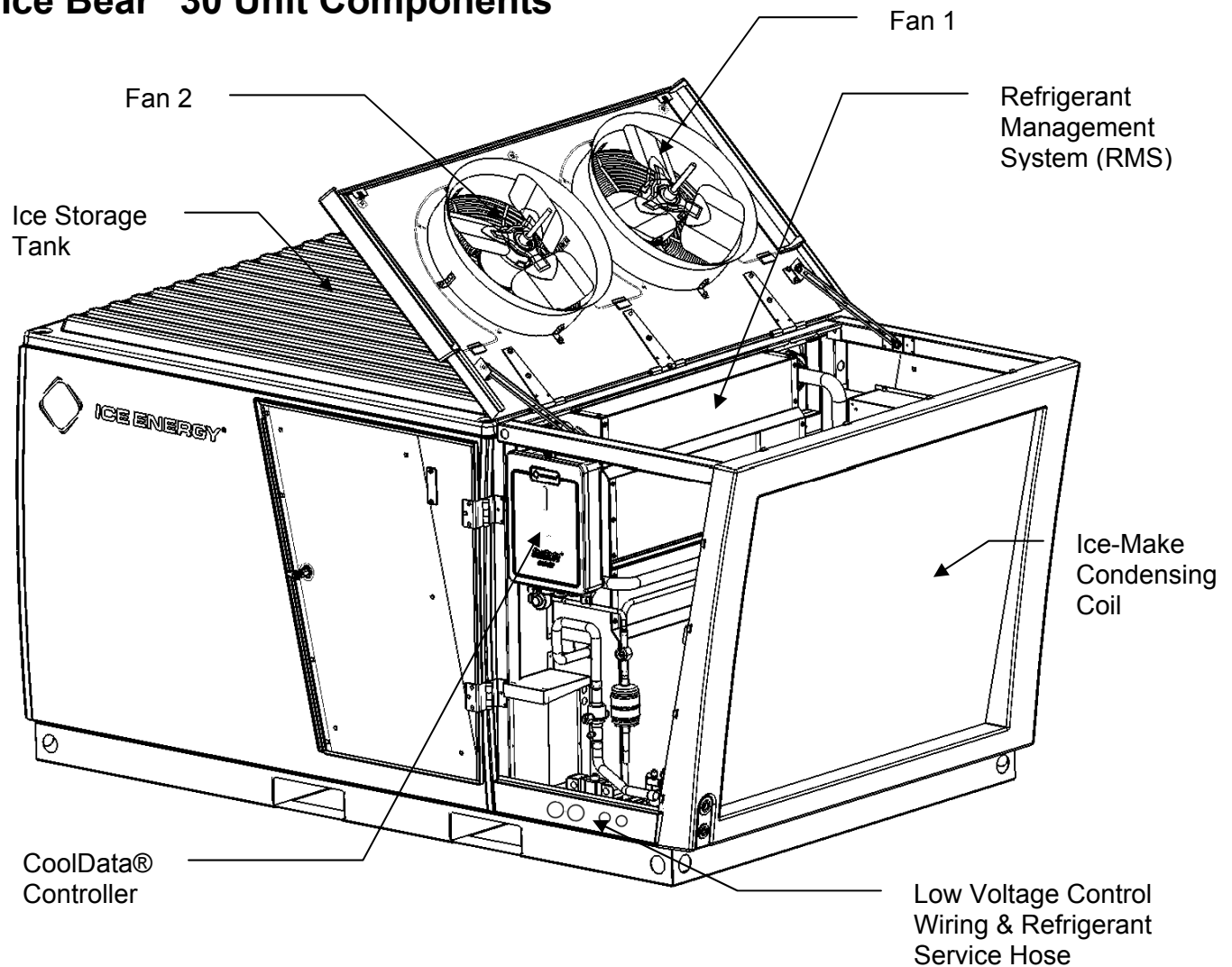

Figure 1 - Ice Bear[®] Unit Exterior Components

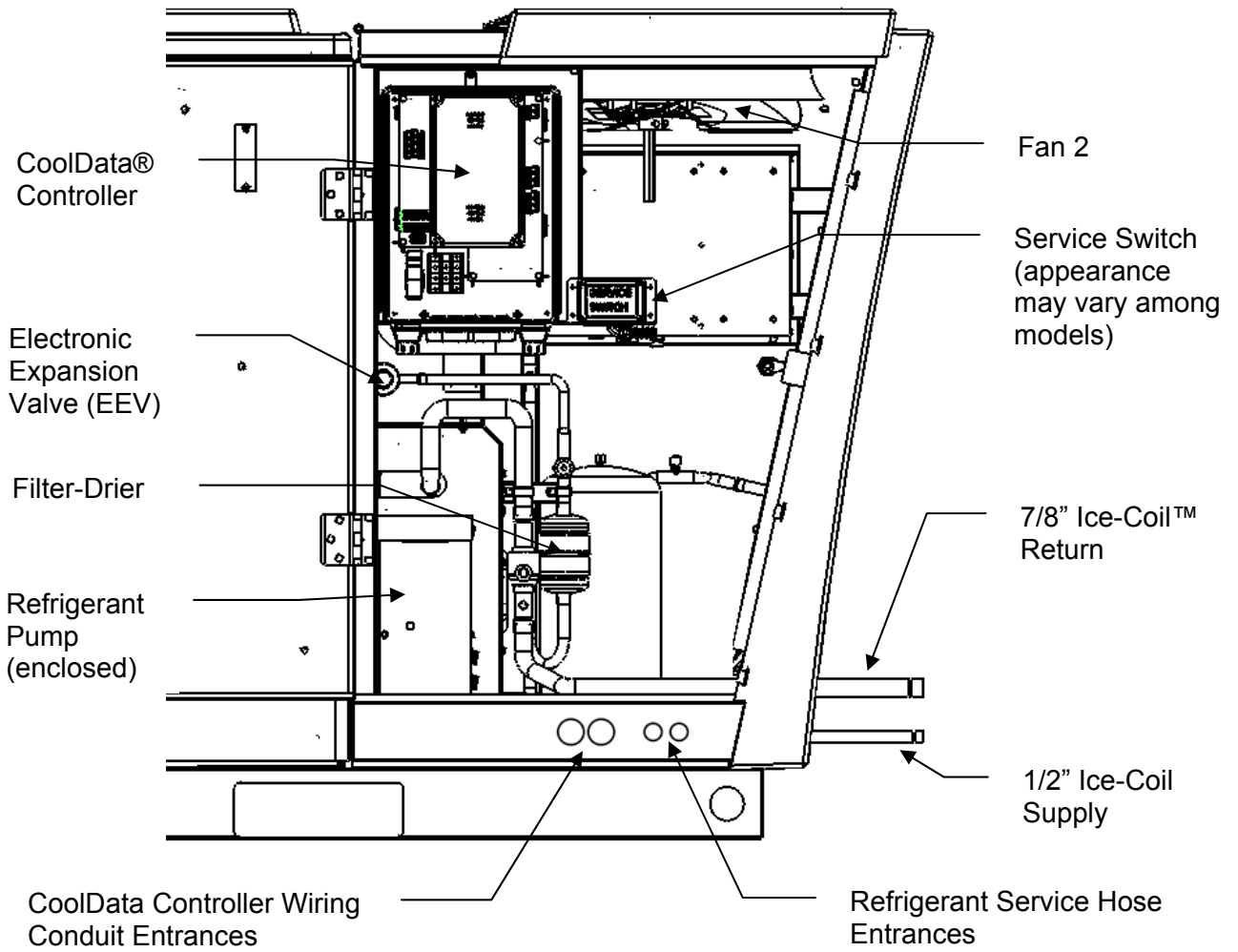

Figure 2 – Ice Bear® Unit Internal Components (Left Side)

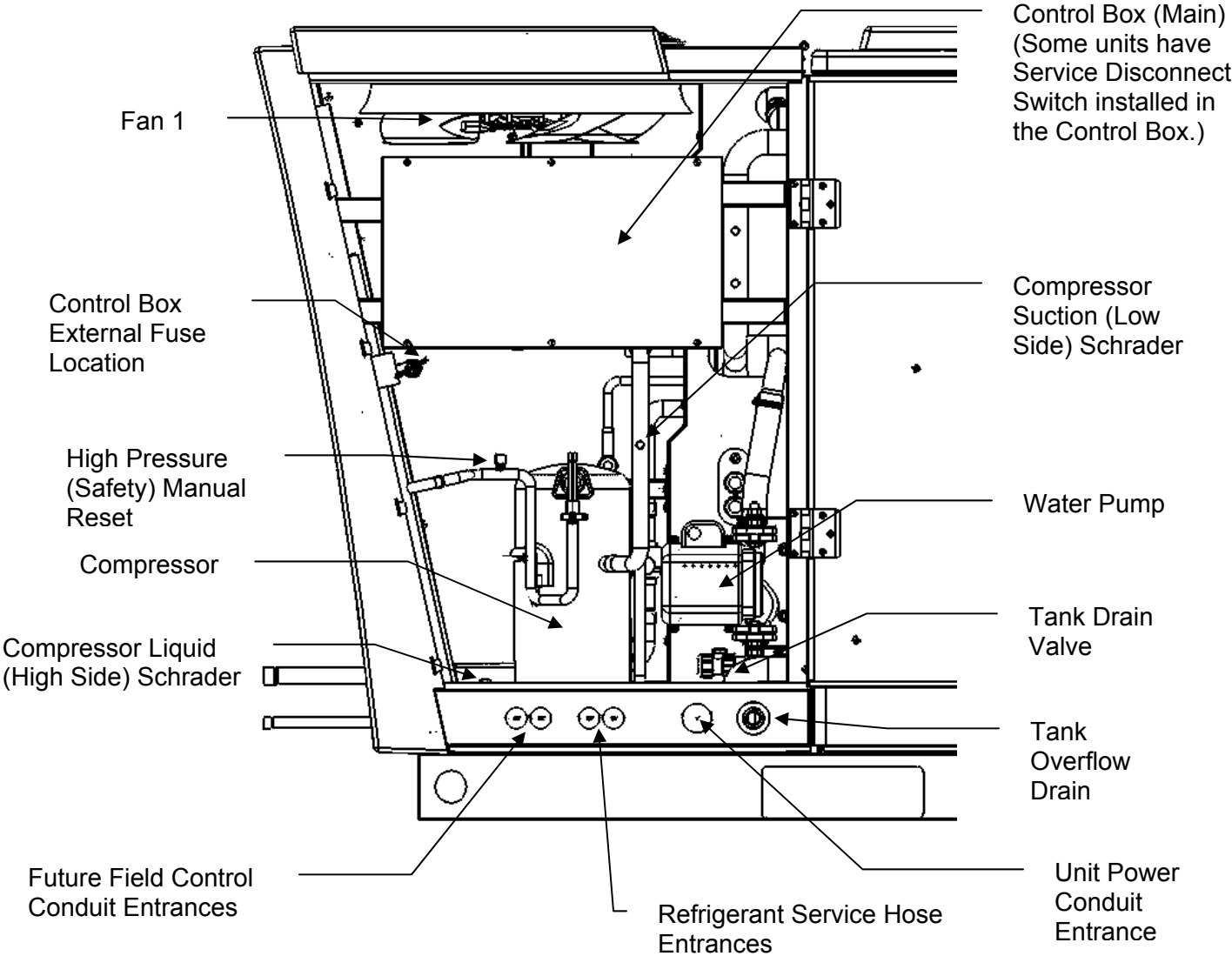

Figure 3 – Ice Bear® Unit Internal Components (Right Side)

Modes of Operation

The Ice Bear unit is capable of operating in the following modes:

- Ice Make mode
 - Night (off-peak) operation
 - Storing energy, charging, making ice
- Ice Cooling mode
 - Peak period operation (call for cooling)
 - Discharging the stored energy, melting the ice

Ice Make Mode

During Ice Make mode, the integral and factory pre-charged Ice Bear condensing unit (R-410A refrigerant and miscible oil) provides low temperature refrigerant to the Ice Bear unit's Refrigeration Management System (RMS). On the secondary side of the RMS, a separate, oil-free R-410A charge automatically circulates through a heat exchanger until the tap water freezes into a solid block of ice.

Ice make is typically 10 hours for a full 30 ton-hour charge and is made during the coolest time of night or when electrical utility rates are at their lowest, or off-peak times.

Why Make Ice?

It takes 1 BTU of energy to lower the temperature of one pound of water 1 °F.

For example, it takes 1 BTU of energy to lower the temperature of one pound of water from 38 °F to 37 °F.

However, it takes 144 BTU's of energy to change the state of one pound of water from a liquid to a solid (ice). Therefore, it takes 144 BTU's of energy to change the state of one pound of 32 °F water from a liquid into ice.

The Ice Bear unit's block of ice is sized to store 30 ton-hours of energy. There are 12,000 BTU's per ton, so the 30 ton-hours of stored energy are equivalent to 360,000 BTU's. A 60,000 BTU/hour cooling load or exactly the cooling load of one 5-ton Ice Coil (12,000 BTU's / ton × 5 tons) running for six hours would consume the entire Ice Make or 360,000 BTU's of stored energy.

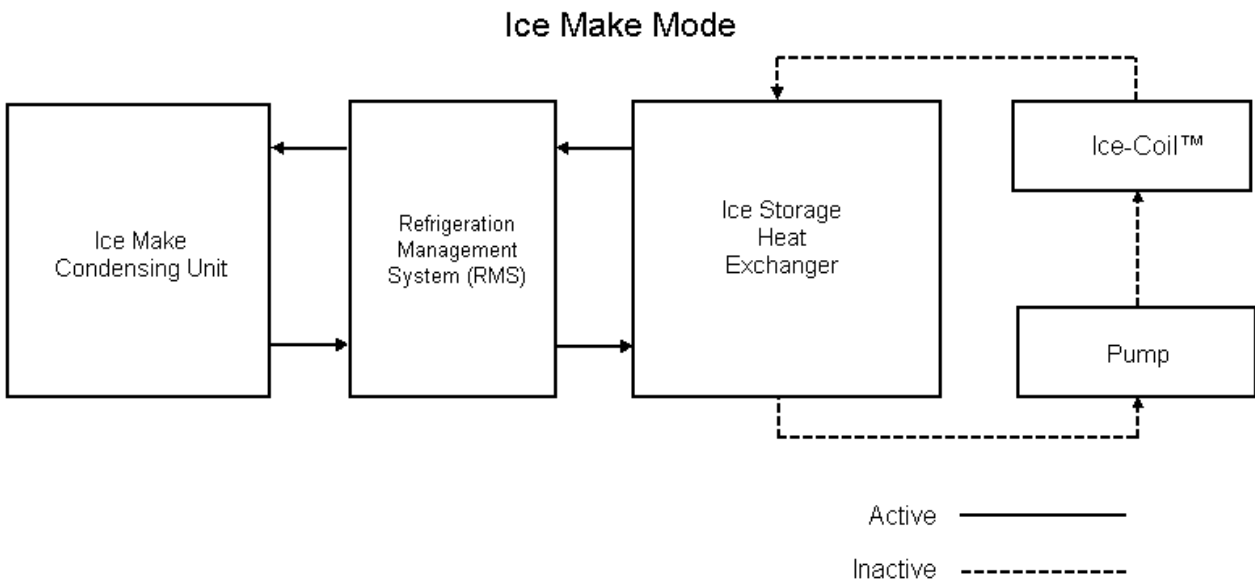

Figure 4 – Refrigerant Flow Schematic – Ice Make Mode

Ice Cooling Mode

During Ice Cooling mode, the integral Ice Bear condensing unit is switched off and typically one 5-ton condensing coil on the Base System is locked out. The Ice Cooling circuit, which includes an ice-on-coil heat exchanger, a refrigerant pump, and Ice-Coil™, are physically isolated from the Ice-Make circuit and its refrigerant charge by a unique receiver/separator. When there is a request for cooling, a refrigerant pump circulates the oil-free liquid R-410A refrigerant through the liquid supply line to an Ice-Coil located in the air stream. Typically this is a Redundant Ice-Coil installed into a packaged rooftop unit or a slab coil mounted in the air supply duct. The vapor return line returns vaporized or mixed phase refrigerant to the Ice Bear unit's ice-on-coil heat exchanger where it melts ice and is condensed back into its liquid state.

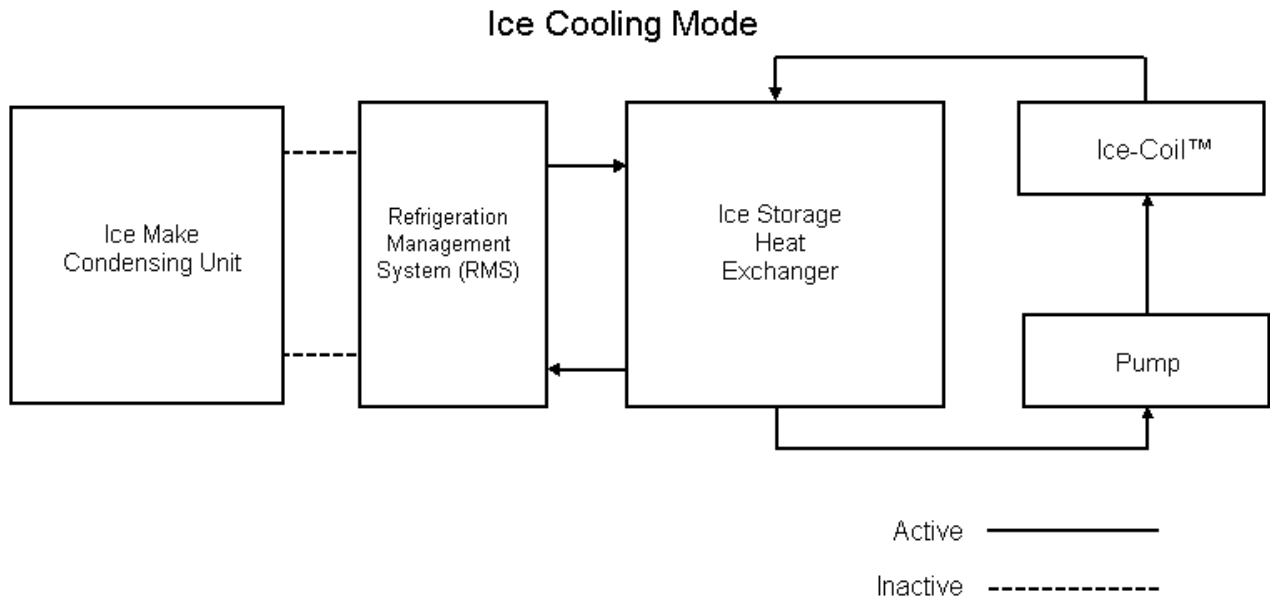

Figure 5 – Refrigerant Flow Schematic – Ice Cooling Mode

CoolData® Controller

Features

The CoolData controller is an advanced control system that provides both controlling and monitoring functions for the Ice Bear unit. Also, the CoolData controller has bidirectional control and communication capabilities for Smart Grid integration, including:

- configuration management
- real-time control
- advanced and optimal control
- real-time status, submetering, and monitoring
- performance analysis and automated diagnostics
- equipment health management
- event capture and analysis
- push and polling communications
- physical & cyber security
- data integrity readied for transactions with enterprise-level communication

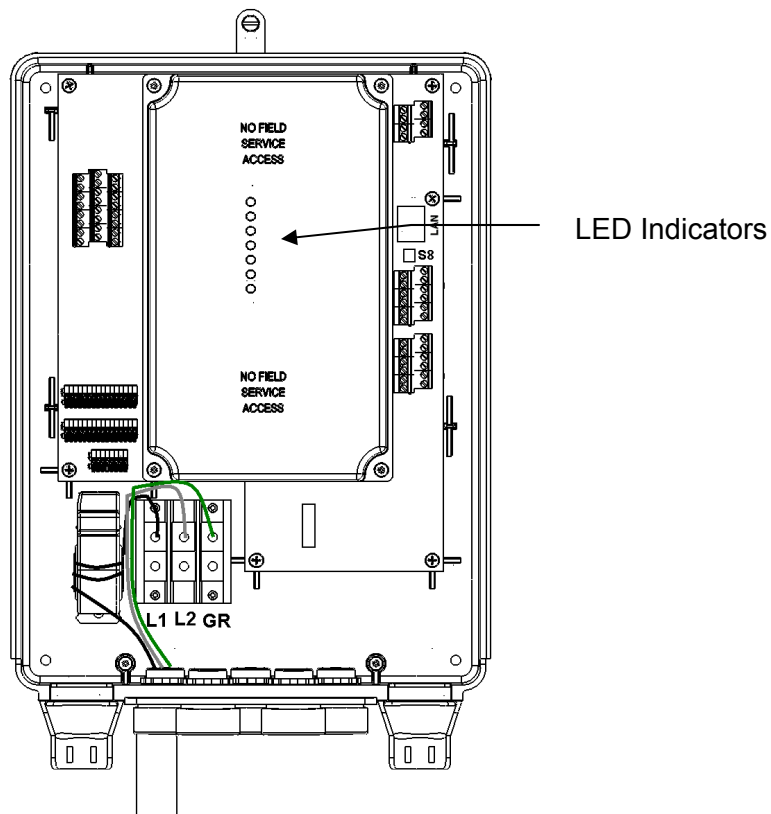

Figure 6 – CoolData® Controller

Control Schematic

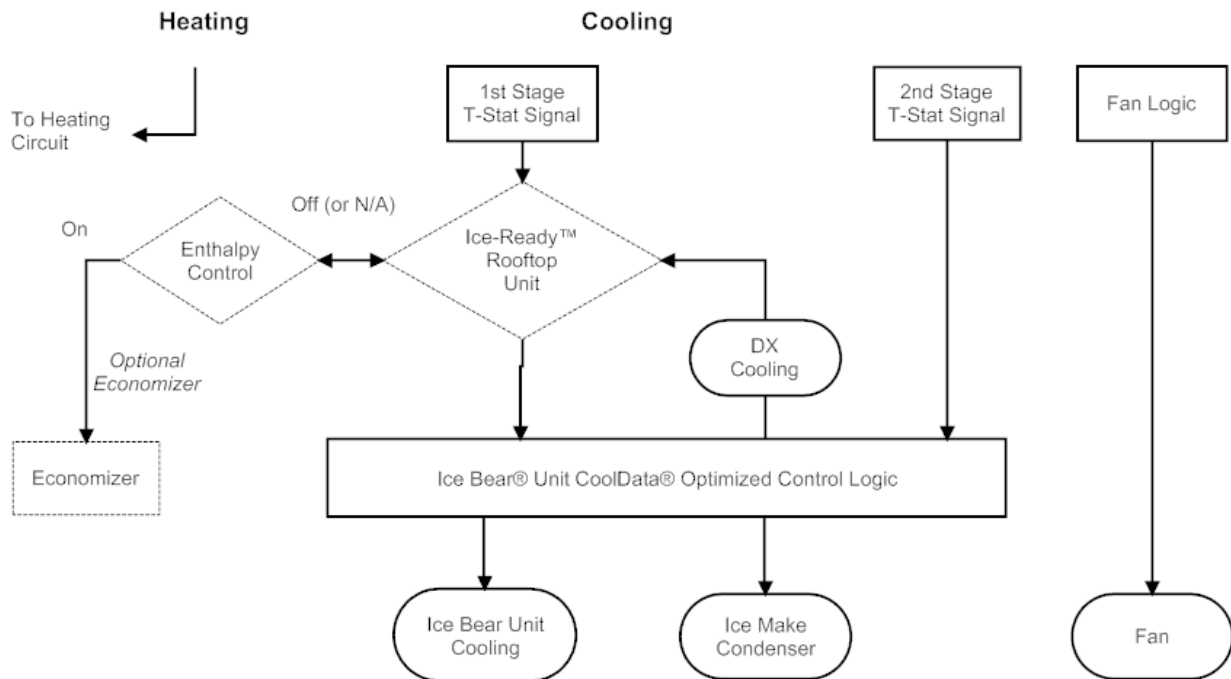

Figure 7 – Control Schematic

Control Configuration Example

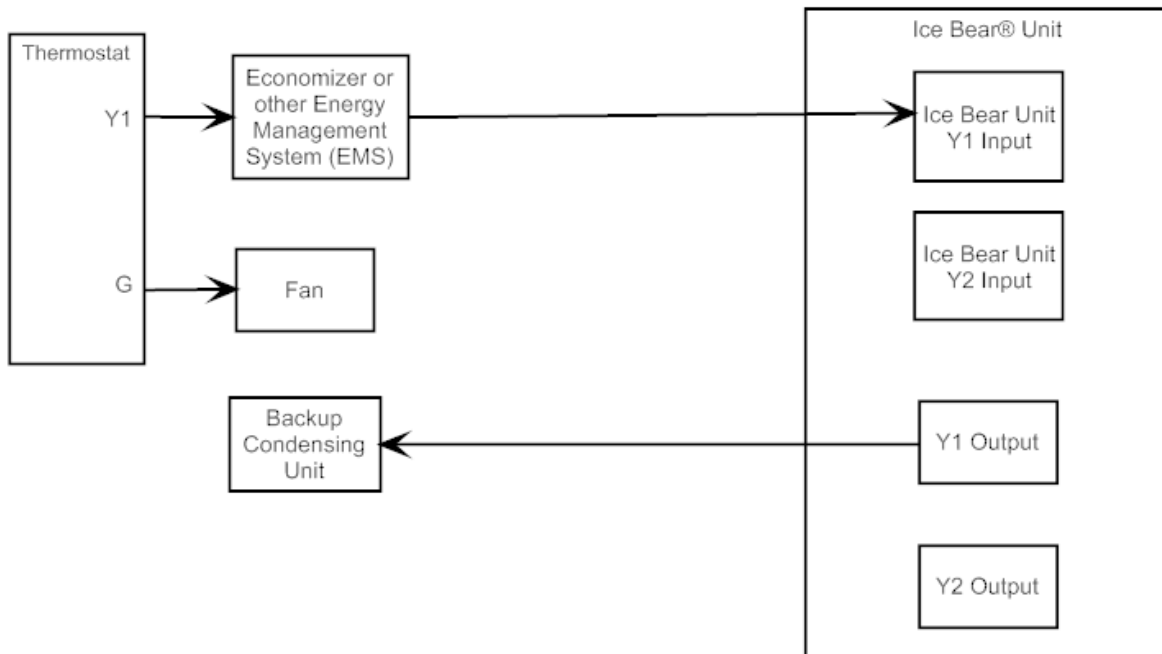

Figure 8 – Single Zone, Single-stage Thermostat with Economizer and Backup Condensing Unit

Applications

Typical Applications

- Single zone
- Single Ice Bear unit or multiple Ice Bear units
- Partial storage system in a multi-stage configuration (displacing one stage of a multi-stage system)

NOTE: When applying an Ice Bear 30 unit to a heat pump, the Ice Bear unit must have a dedicated (redundant) Ice-Coil.

Sample Ice Bear[®] Unit Configurations

- Ice Bear unit (parallel) with Ice-Ready[™] rooftop unit
- Redundant (parallel) split system

Ice Bear[®] Unit (Parallel) with an Ice-Ready[™] Rooftop Unit

The Ice Bear unit can be integrated with a modified packaged rooftop unit called an Ice-Ready rooftop unit. The Ice-Ready rooftop unit, illustrated in the figure below, is a standard rooftop unit that has been modified to include an additional liquid overfeed evaporator coil (Ice-Coil[™]) that is dedicated to the Ice Bear unit.

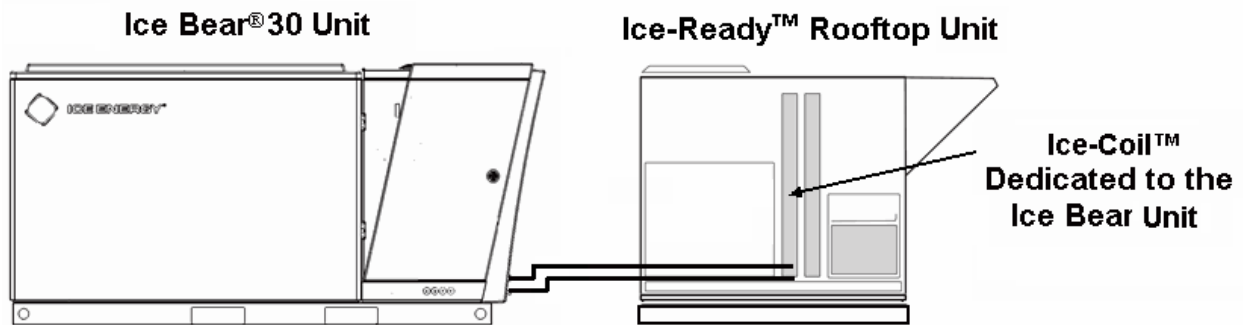

Figure 9 – Ice Bear[®] Unit (Parallel) with Ice-Ready[™] Rooftop Unit

Redundant (Parallel) Split System

In a redundant split system, the Ice Bear unit is part of a separate and parallel redundant refrigerant loop. It is only designed to take on a load for a designated period of time. The liquid overfeed coil (connected to the Ice Bear unit) is placed downstream of the existing or “regular” standard DX coil. The Ice Bear unit handles the designated load during peak load conditions, while the rest of the system handles the cooling load during the remainder of the day.

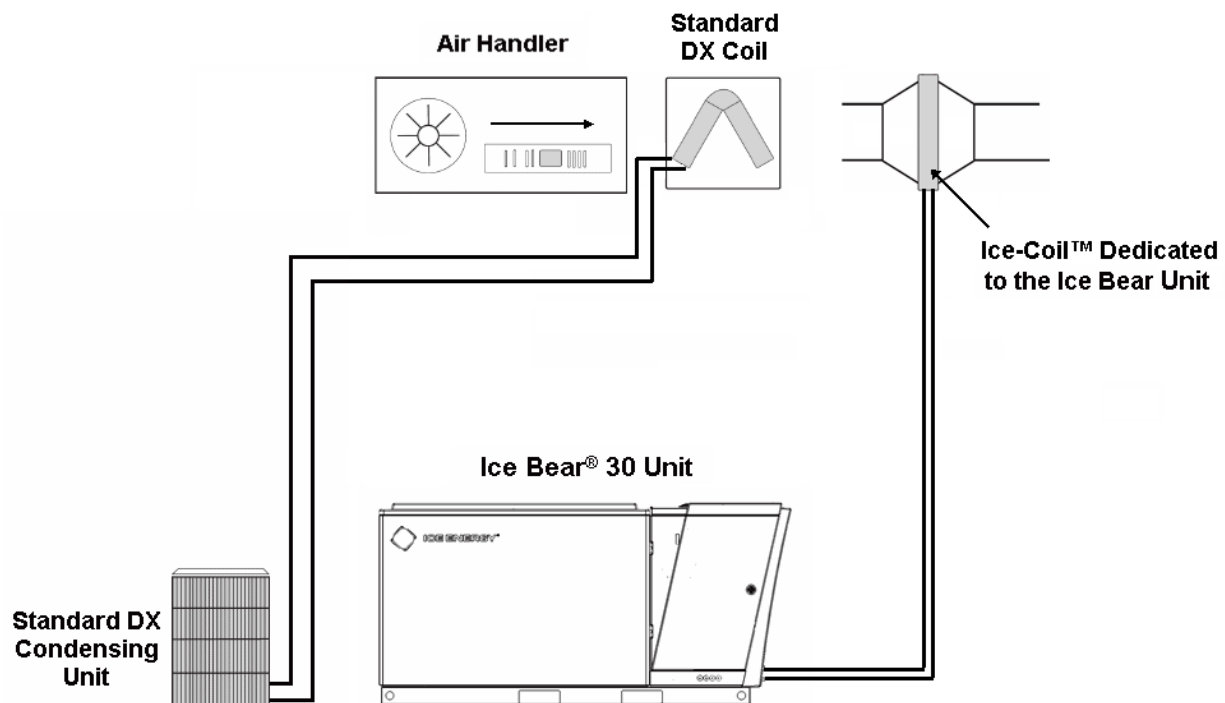

Figure 10 – Redundant (Parallel) Split System

Pre-installation

General Precautions & Responsibilities

- Installation by anyone other than an Ice Energy-certified installer voids warranty.
- Consult with structural engineer where applicable.
- Comply with existing governmental electrical codes. In the absence of local codes, the installation must conform to the National Electrical Code (NEC), ANSI/NFPA 70, as amended.
- Comply with EPA proper refrigerant handling & transportation practices.
- Adhere to the minimum and maximum air flow limits for condensing units and evaporator coils.
- After unit is set, remove packaging.
- Ensure that:
 - Existing mechanical equipment has been evaluated for performance and level of maintenance. Document your findings.
 - The cooling system design has been reviewed and approved by the appropriate heating, venting and air conditioning system designer.
 - The building's existing electrical system will accommodate the additional equipment.
 - All permits required for installation have been obtained from the appropriate authority having jurisdiction.

Required Tools/Accessories

- digital micron vacuum gauge
- vacuum pump (10 CFM recommended)
- electronic refrigerant leak detector
- potable water supply
- brazing equipment

Transporting the Ice Bear® Unit

- Forklift slots are located on the bottom of the ICE BEAR UNIT. See Figure 11 for dimensions.

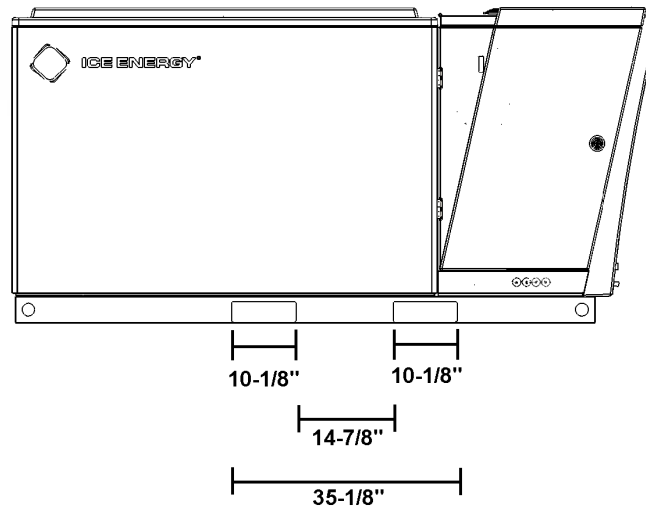

Figure 11 – Ice Bear® 30 Unit Forklift Slot Dimensions

- Forks must be a minimum of 4 ft. long to properly accommodate the ICE BEAR UNIT.
- Ensure that all lids and covers are bolted securely before transporting.
- When moving the ICE BEAR UNIT using a crane or boom truck, refer to *Ice Bear® 30 Unit Lifting Instructions* later in this manual.
- See *Appendix A – Product Specifications* for weights, overall dimensions, and center of gravity dimensions.

Installation

Minimum Clearances

In addition to the minimum clearances depicted in the figures below, ensure that a 60" vertical clearance exists to provide for proper CONDENSER FAN operation. Note that Figure 12 covers clearances for ICE BEAR UNITS with a unit-mounted SERVICE DISCONNECT SWITCH. For ICE BEAR UNITS with an internal SERVICE DISCONNECT SWITCH (located in the ELECTRICAL CONTROL BOX), refer to Figure 13.

NOTE: Local codes/regulations may prevail.

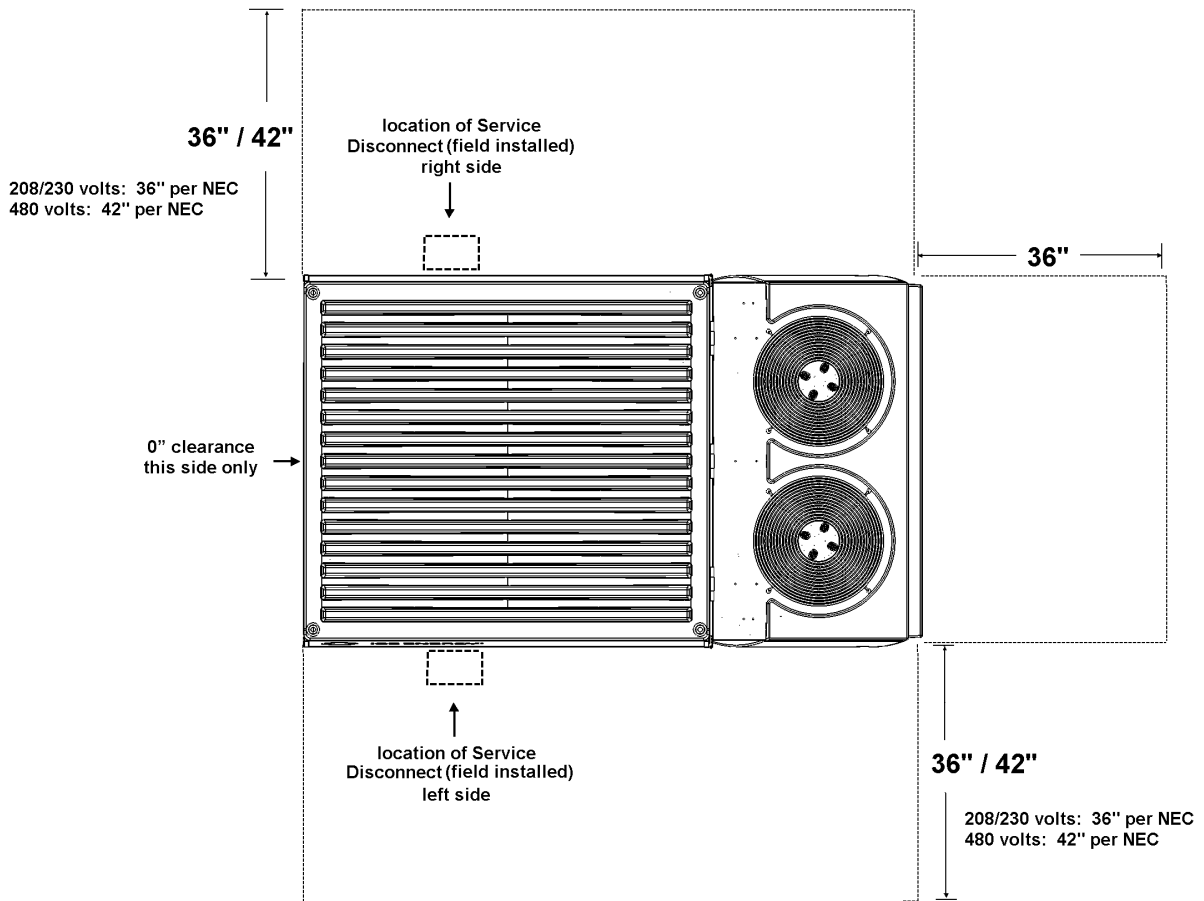

Figure 12 – Minimum Clearances for Unit-mounted Service Disconnect

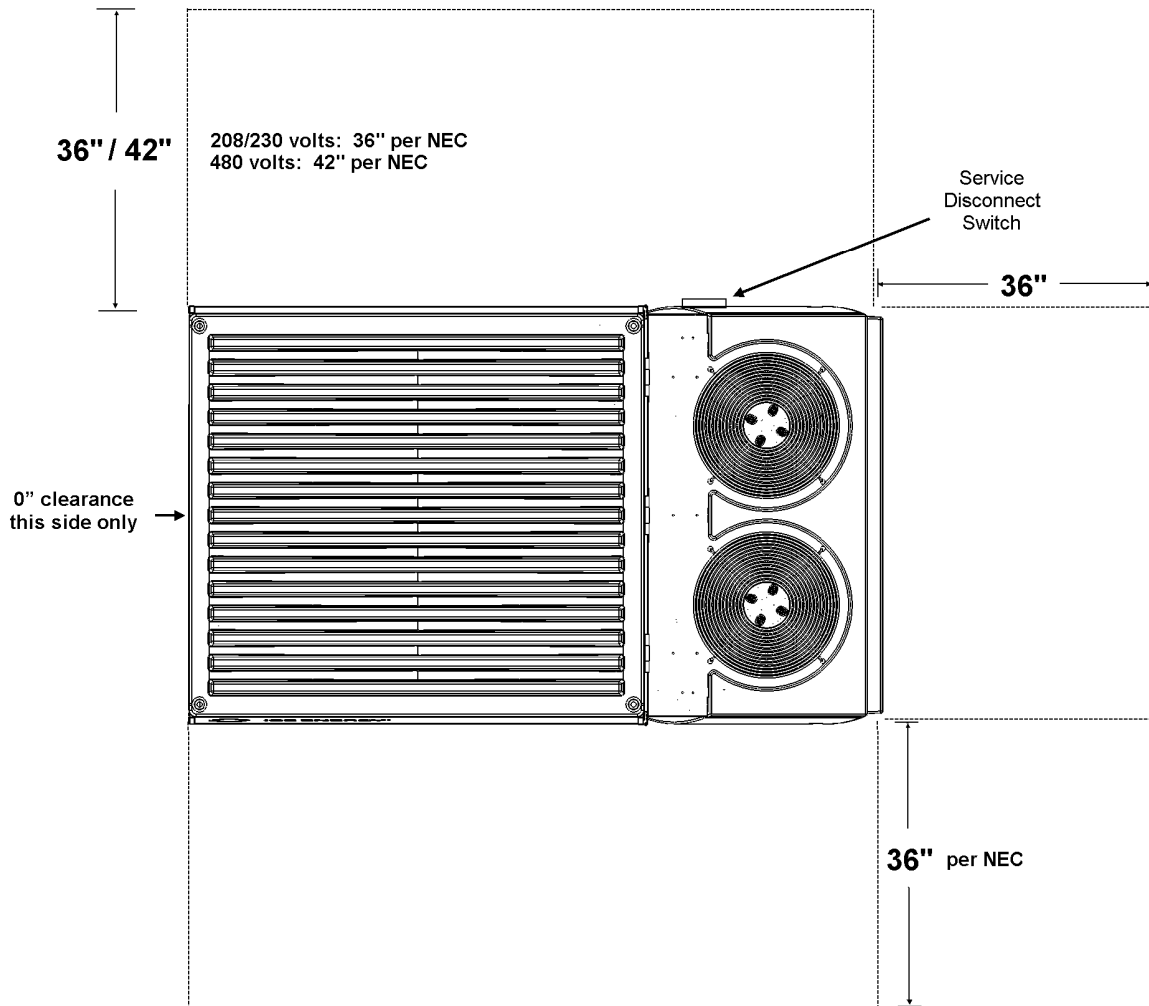

Figure 13 – Minimum Clearances for Units with Internal Service Disconnect Switch

Ice Bear[®] 30 Unit Lifting Instructions

The lifting instructions below provide a safe, level lift that also protects the integrity of the equipment.

CAUTION: Any lifting method other than the technique described below may cause damage to the exterior components of the unit. Ice Energy is not responsible for any damage caused by alternative lifting techniques (i.e., damage is not covered by the product warranty).

NOTE: Use 2” or 3” wide nylon straps only. Steel choker cables will damage unit sides.

This method involves using a 10’ spreader bar and two cross bars in an “H” configuration (see Figure 15).

1. Attach (4) SHACKLES and LIFT STRAPS (10’ long) using lifting points called out in Figure 14.
2. Attach other ends of LIFTING STRAPS to SHACKLES located on the crane’s spreader bar. Ice Energy recommends a 10’ spreader bar in an “H” configuration with two 6’- 8’ bars running perpendicular (see Figure 15).
3. Adjust spreader bar so that LIFTING STRAPS do not touch the ICE BEAR UNIT.
4. Lift the ICE BEAR UNIT approximately 6” high to check leveling from side to side and back to back.
5. Lift the ICE BEAR UNIT, as appropriate.

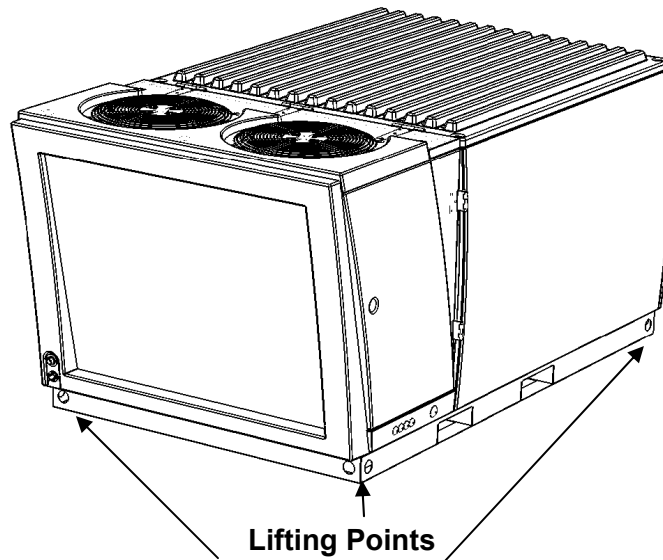

Figure 14 – Ice Bear[®] 30 Unit Lifting Points

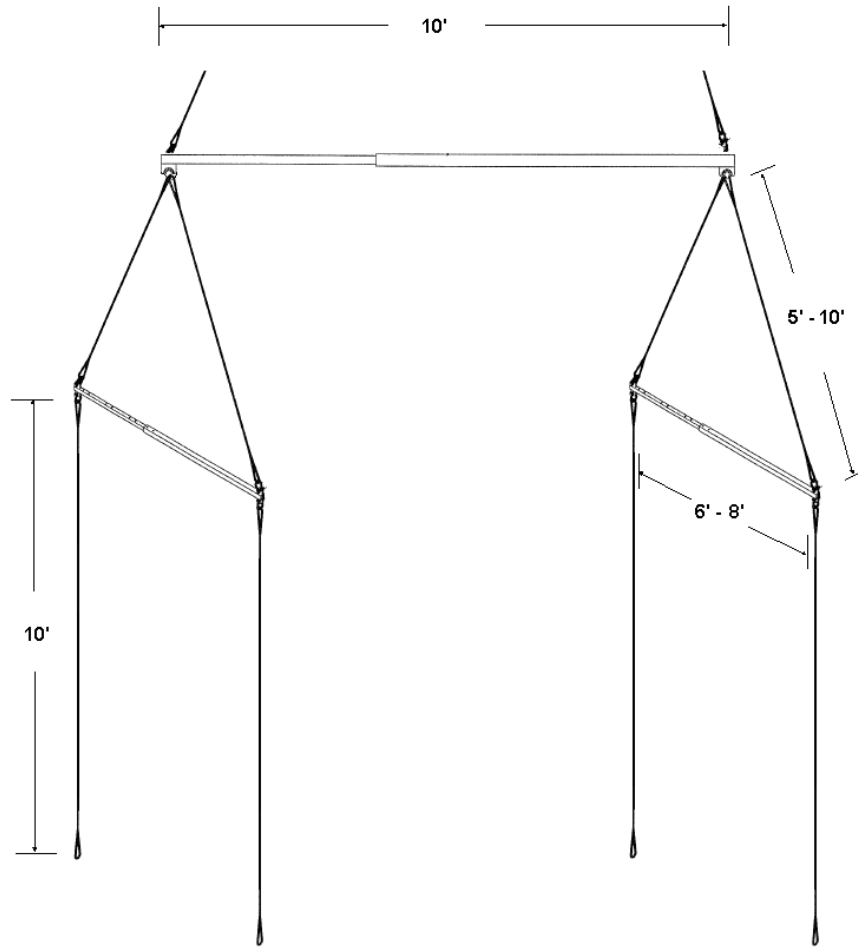

Figure 15 – Required Spreader Bar Configuration

Mounting

Preparation

- Follow structural drawings for proper location of the ICE BEAR UNIT. Consult a Structural Engineer.
- Provide leveling in compliance with local codes for clearance, easements, and soil compaction restrictions. The ICE BEAR UNIT must be level to within 1/8" in all directions.
- See Figure 12 and Figure 13 for minimum access clearances.
- See *Appendix A – Product Specifications* for wet (water-filled) center of gravity dimensions.
- Consult local codes for any required seismic restraints.

Rooftop Mounting

1. Lift the assembly up to the building's rooftop following the *Ice Bear® 30 Unit Lifting Instructions* in this manual.
2. Position ICE BEAR UNIT over structural curb with cap (see Figure 18).
3. Remove SHACKLES and LIFTING STRAPS from the UNIT.
4. Secure ICE BEAR UNIT per local code.

See Figure 16 for an illustration of a typical rooftop installation (steel support structure).

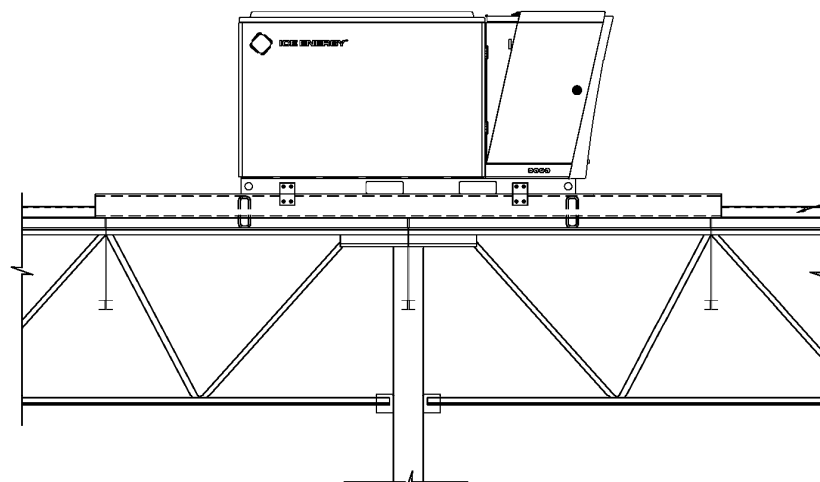

SIDE VIEW

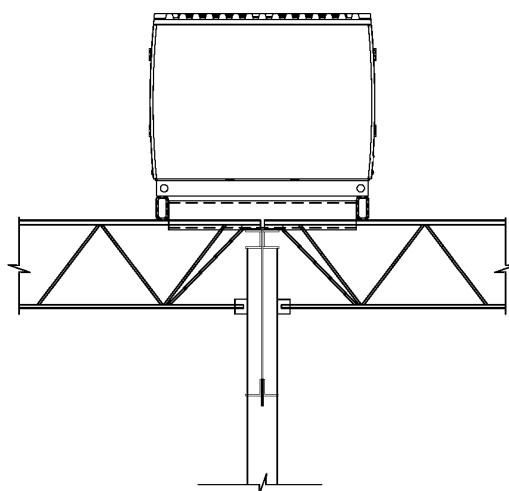

REAR VIEW

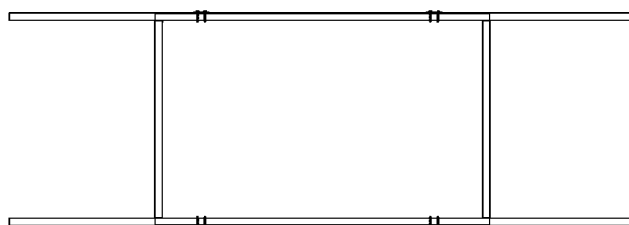

SUPPORT LAYOUT

Figure 16 – Typical Roof Mount Installation (Steel Support Structure)

See Figure 17 for an illustration of a typical rooftop installation (wooden support structure).

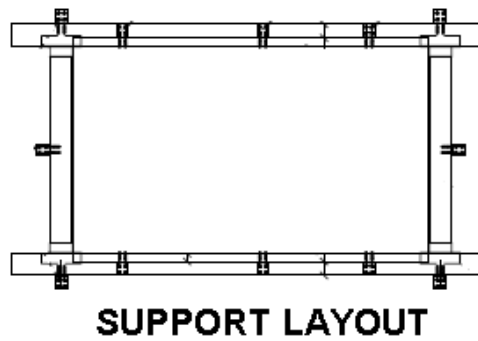
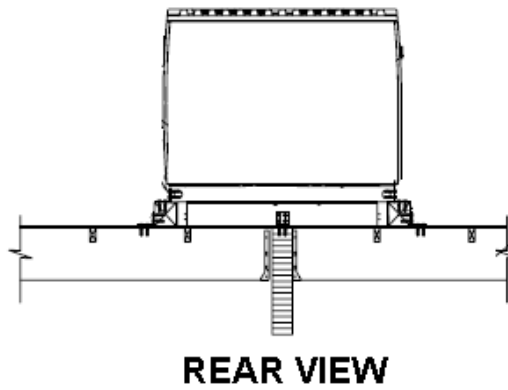
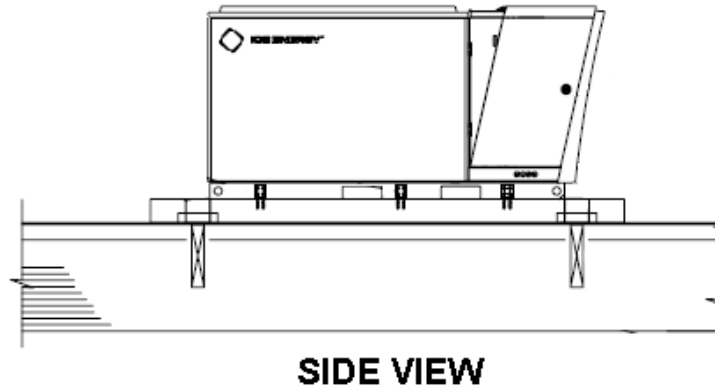

Figure 17 – Typical Roof Mount Installation (Wooden Support Structure)

Figure 18 illustrates an ICE BEAR UNIT mounted on a structural curb with cap. Contact Ice Energy for details.

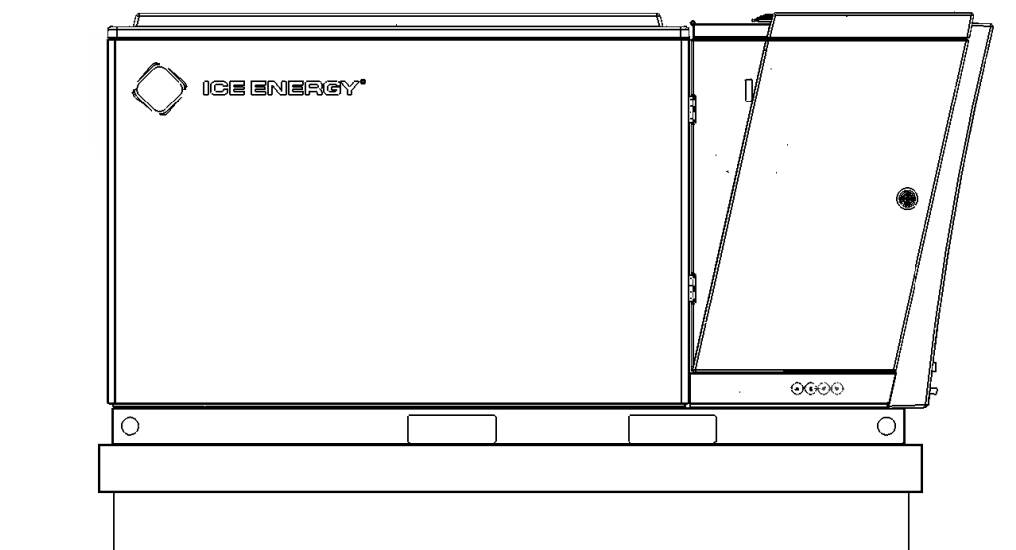

Figure 18 – Ice Bear[®] 30 Unit on Structural Curb with Cap

Ground Mounting

- A concrete pad or other approved surface may be used, as designed and reviewed by a licensed structural engineer.
- See *Appendix A – Product Specifications* for ICE BEAR UNIT weights and dimensions.
- See Figure 19 for minimum recommended pad dimensions.
- Figure 20 provides a sample drawing of a precast concrete pad.

NOTE: Local codes/regulations may prevail.

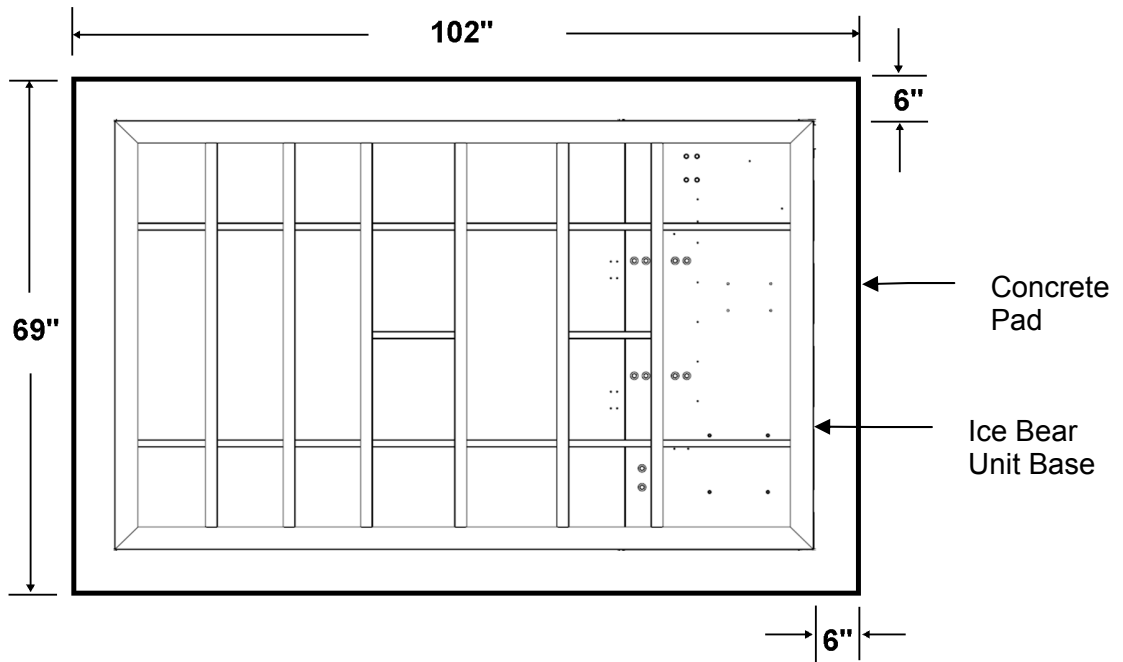

Figure 19 – Minimum Recommended Concrete Pad Dimensions

! CAUTION

If concrete pad is installed directly against building's foundation, an approved expansion joint must be installed to prevent possible noise transfer.

Ensure that roof drainage system does not undermine the ICE BEAR UNIT's foundation and that ALL gutters and downspouts are properly placed and secured.

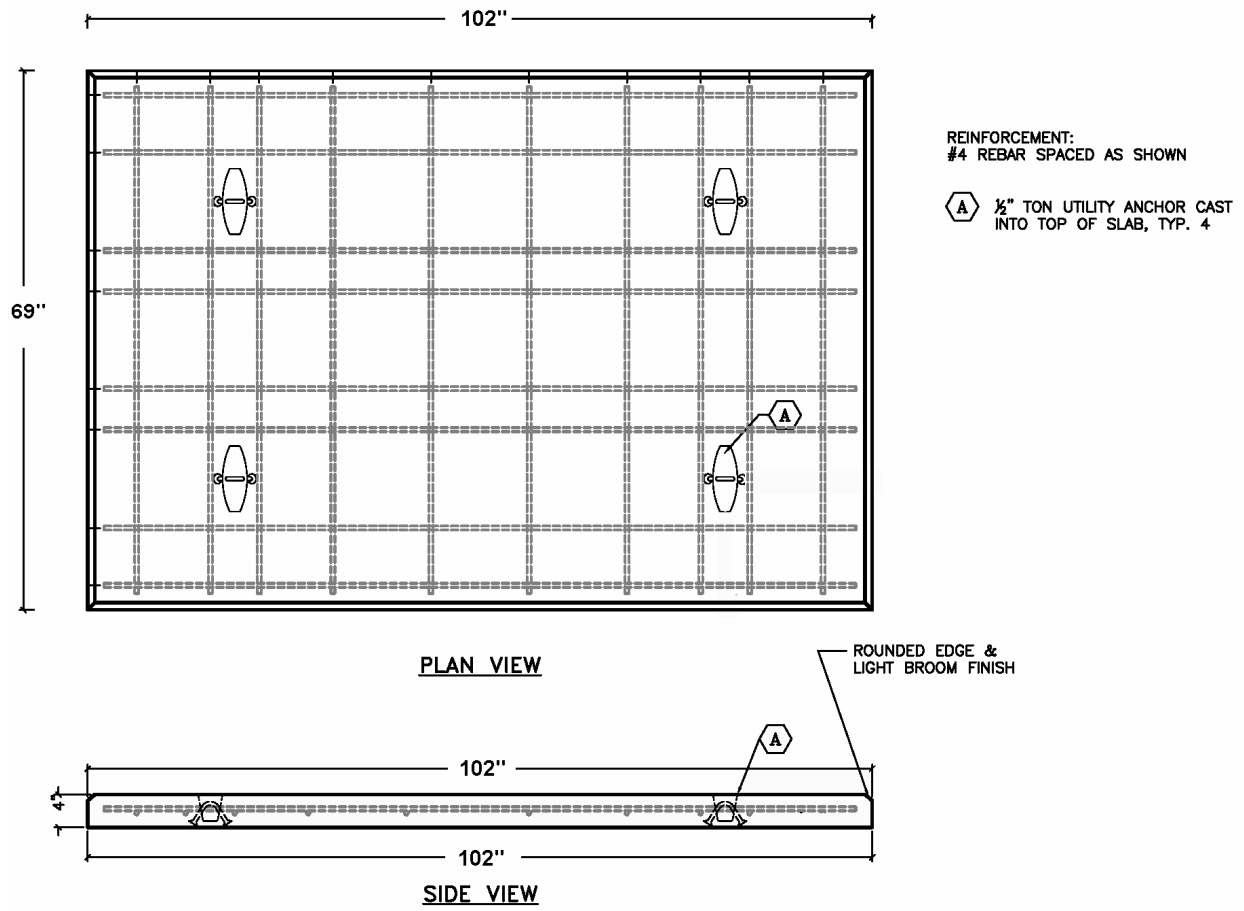

Figure 20 –Sample Precast Concrete Pad

Refrigerant Piping

This section includes the following steps:

1. Field Piping
2. Leak Testing
3. Evacuation
4. Releasing Unit Refrigerant Charge

1. Field Piping

! WARNING

The Schrader SERVICE PORTS are used for vacuuming and charging refrigerant in the system.

The unit is shipped with the following charges:

| Component | Factory Charge |
|-----------------------|-------------------|
| COMPRESSOR (Ice Make) | 11 lb 8 oz R-410A |
| TANK (Ice Cooling) | 35 lb R-410A |

NOTE: Units are shipped pre-charged.

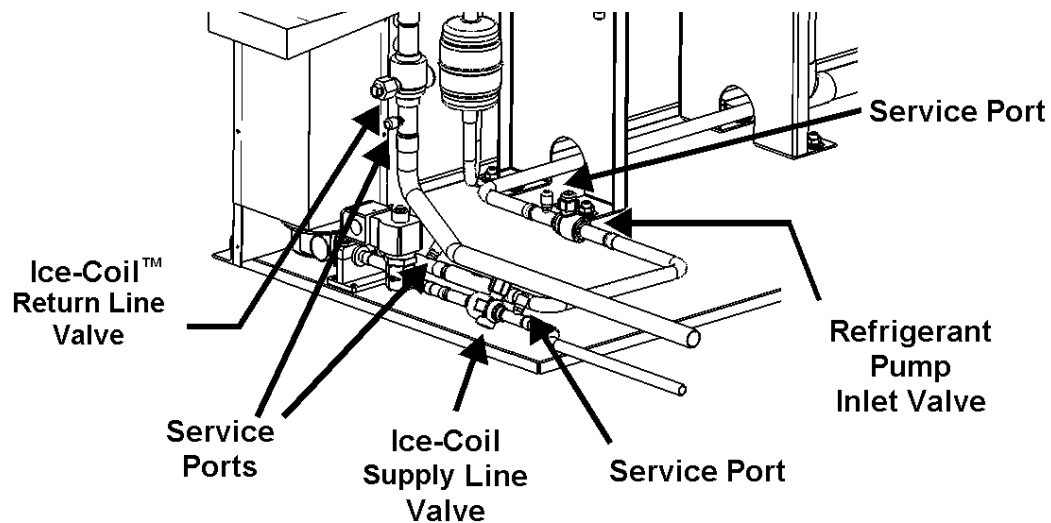

Figure 21 – Valve Locations

1. Verify ICE-COIL return line and ICE-COIL supply line VALVES are in the shipped **fully closed** position. Attach refrigerant manifold gage hose to each VALVE SERVICE PORT and relieve any residual pressure.
2. Remove the CAPS off of the ends of the ICE-COIL supply line and the ICE-COIL return line.
3. Using refrigerant grade type L (ACR) copper, connect the 1/2" ICE-COIL supply line to the ICE BEAR UNIT's ICE-COIL supply line (reference Figure 22).

4. Install a field-provided 1/2" minimum 16 cubic inch FILTER-DRIER and 1/2" moisture-indicating SIGHT GLASS on the ICE-COIL supply line at the ICE BEAR unit.
5. Connect the 7/8" ICE-COIL return line to the ICE BEAR UNIT's ICE-COIL return line (reference Figure 22).
6. Braze all field-installed piping and fittings.

NOTE: New refrigerant lines must be purged with a small amount of nitrogen while brazing to minimize oxidation contamination.

NOTE: Both ICE-COIL refrigerant lines must be insulated.

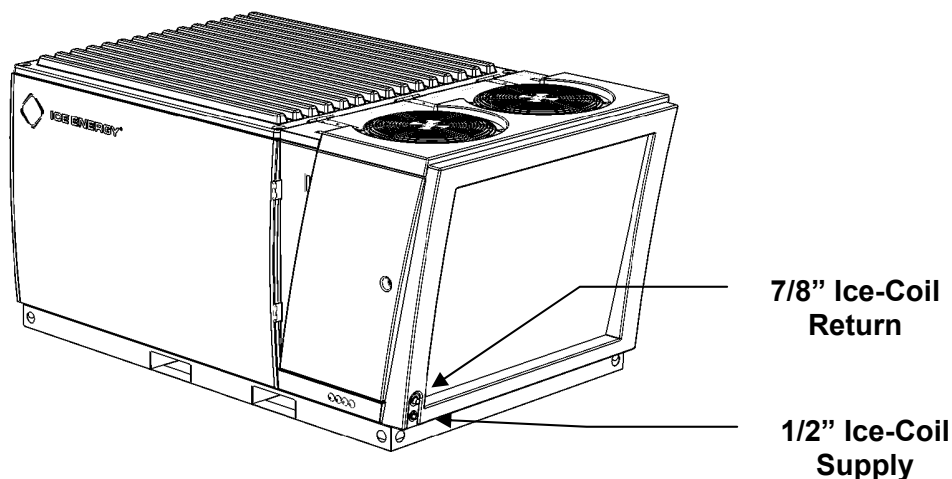

Figure 22 – Refrigerant Piping Connection Points

NOTE: All piping must adhere to the specifications called out in the following table.

Line Set Specifications

| Item | Specification |
|--|--|
| Line Set Sizing | ICE-COIL™ supply line = 1/2" ICE-COIL return line = 7/8" (Both lines must be insulated.) |
| Maximum overall length (to ICE-COIL) | 150 ft including vertical head (maximum 20 fittings) |
| Maximum vertical head ICE-COIL supply line | 35 ft |
| Maximum vertical head ICE-COIL below ICE BEAR UNIT | 20 ft |
| Maximum fittings per line (supply & return) | 20 |
| Minimum insulation wall thickness | 1/2" or minimum required by local code, whichever is greater. |
| SERVICE PORTS | SERVICE PORTS must be field installed in the ICE-COIL supply and return lines, as close as possible to the COIL. |

Refer to the applicable *Ice-Ready Rooftop Unit Installation Instructions* for instructions on piping between the Ice-Ready rooftop unit and the Ice Bear unit.

2. Leak Testing

1. Once all the connections to the ICE-COIL from the ICE BEAR UNIT are completed, the system must be tested for leaks.
2. Using a manifold gauge set, make the following SERVICE PORT connections:
 - Low pressure gauge to the ICE-COIL supply line VALVE SERVICE PORT.
 - High pressure gauge to ICE-COIL return line VALVE SERVICE PORT.
3. With both manifold VALVES closed, connect a cylinder of R-410A refrigerant. Open the cylinder VALVE on the R-410A cylinder. Purge manifold and hoses following EPA standards *before* allowing refrigerant into the line set. Open the high pressure side of the manifold to allow R-410A vapor into the line set, weighing in a trace amount of R-410A.
4. Close the VALVE on the R-410A cylinder and the VALVE on the high pressure side of the manifold gauge set. Disconnect the R-410A cylinder.
5. Connect the nitrogen supply with a pressure regulating valve to the charging/evacuation PORT of the manifold gauge set.

NOTE: The nitrogen pressure should NEVER exceed the refrigerant pressure in the rest of the system.

6. Adjust nitrogen pressure to 150 psig (using the high side of the manifold is recommended to prevent damage to the low pressure gauge).
7. Open the VALVE on the high side of the manifold gauge set to pressurize the system.
8. After two minutes, crack a refrigerant PORT and test with an electronic leak detector to ensure that the refrigerant you added can be detected.
9. Check all field piping joints. Note any leaks.
10. Purge the nitrogen and trace R-410A mixture.
11. Correct any leaks and recheck.
12. Replace all CAPS and DUST COVERS.

3. Evacuation

Materials Required

- Evacuation pump (6.5 CFM minimum)
- Electronic vacuum gauge (manifold gauge not recommended)
- Two (2) Schrader core remover tools

General Notes

- Read, understand, and follow the evacuation pump manufacturer's operating and servicing instructions.
- Evacuate refrigerant line set and ICE-COIL side of system to 500 microns or less. Measure with an electronic vacuum gauge at a point farthest from the vacuum connections to get a "true" reading.
- Schrader core removers are recommended to facilitate a timely and efficient system evacuation. Manifold gauges are not recommended for evacuating.
- Recommended hose connection points (to ensure complete nitrogen and contaminant removal, always evacuate from the highest connection point in the system):
 - access port on ICE-COIL supply line VALVE inside the ICE BEAR RMS area (see Figure 23)

- access port on ICE-COIL return line VALVE SERVICE PORT inside the ICE BEAR RMS area (see Figure 23)
- access port(s) at the ICE-COIL (reference ICE-COIL installation instructions)
- Use two (2) Schrader core remover tools to remove VALVE cores prior to attaching two (2) evacuation hoses.

NOTE: Connect hoses to the vacuum tree on the vacuum pump, verifying tightness of connections at all points prior to starting evacuation.

Evacuation Procedure

After connecting hoses, start vacuum pump with vacuum pump ballast open. After pump quiets down from initial volume of air, close ballast valve and continue evacuating.

NOTE: Failure to close ballast valve will result in poor pump performance.

1. Evacuate system to 1500 microns, break vacuum with nitrogen to 0 psig. Let system set for a minimum of 15 minutes before proceeding to Step 2.

NOTE: A new system should reach this point within ½ hour. If a new system does not reach target level, terminate evacuation procedure and begin leak detection.

2. Evacuate system to 1000 microns, break vacuum with nitrogen to 0 psig. Let system set for a minimum of 15 minutes before proceeding to Step 3.
3. Evacuate system to 500 microns, valve off vacuum pump and observe vacuum gauge. System should hold steady at 500 microns for 15 minutes. An allowable rise to 750 microns before stabilizing is acceptable.

4. Releasing Unit Refrigerant Charge

1. Upon completion of evacuation procedure, reinstall Schrader cores if removed from SERVICE VALVE PORTS.
2. Release system refrigerant charge by slowly opening ICE-COIL supply line and return line SERVICE VALVES.
3. Replace all Schrader CAP COVERS.

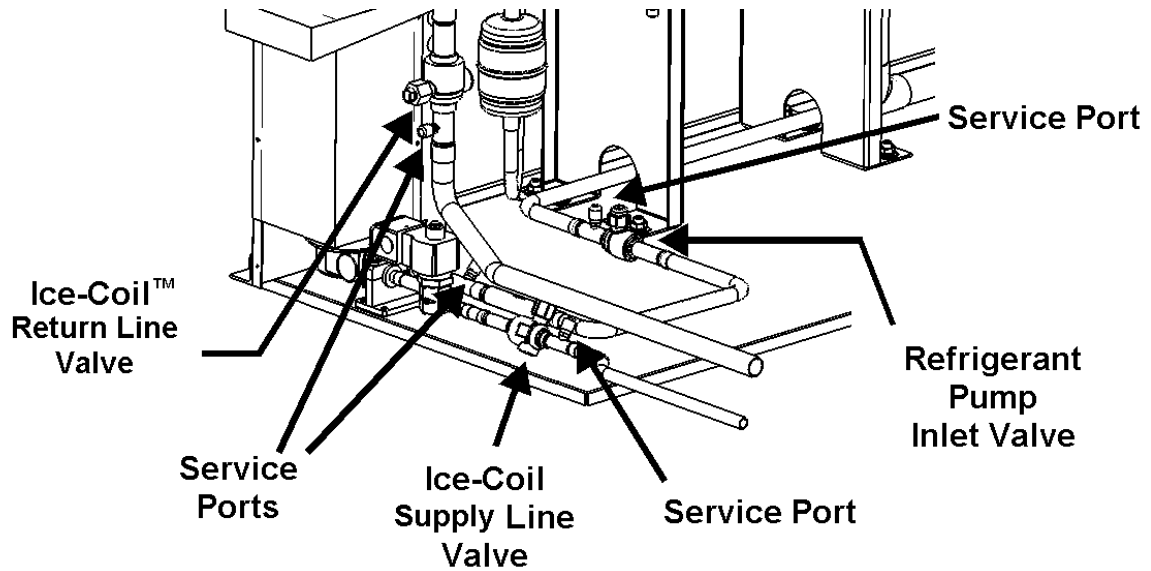

Figure 23 – Valve Locations

Filling Ice Storage Tank

1. Remove ICE STORAGE TANK packaging.
2. Fill the ICE STORAGE TANK with potable water to the bottom of the top PIPE on the HEAT EXCHANGER (see Figure 24). Be sure drainage is in compliance with state/local codes and regulations.

NOTE: Do not fill the ICE STORAGE TANK with water when the system is under a vacuum.

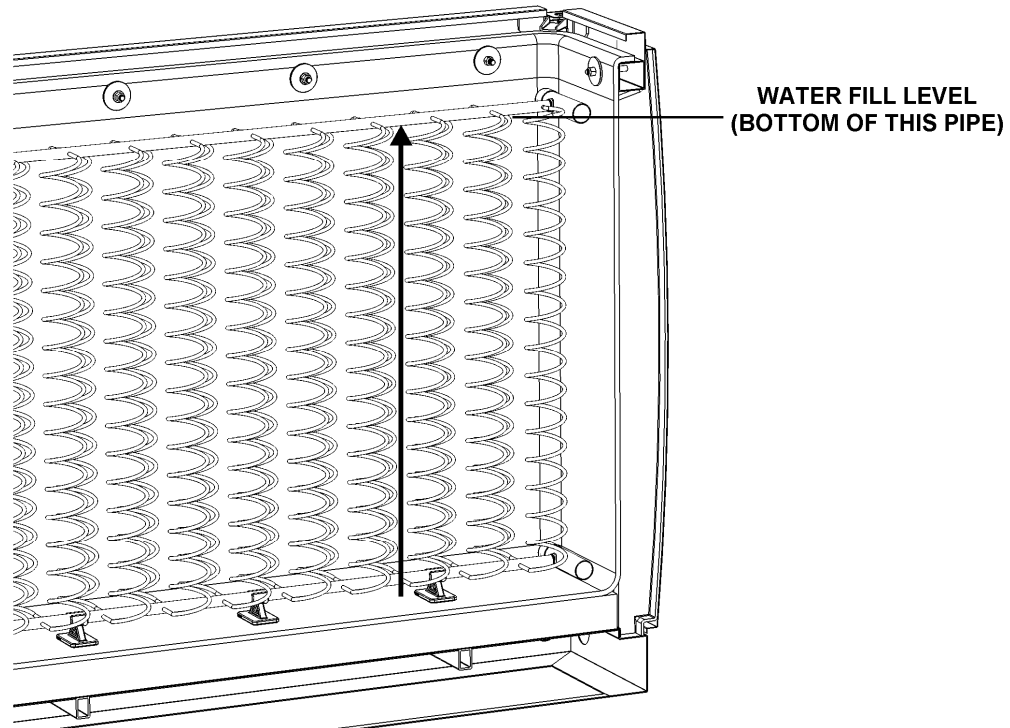

Figure 24 – Ice Bear[®] Unit Water Fill Level

3. Add provided biocide to the ICE STORAGE TANK while it is filling.

Link-Seal® Adjustments

During transit of the ICE BEAR UNIT, it is possible for LINK-SEALS surrounding the upper and lower COLLECTION HEADERS to loosen, causing leakage. If you notice any water leaking from the LINK-SEALS, follow the procedure below to ensure proper sealing.

1. Within the Refrigeration Management System (RMS) area, compress (or remove, if necessary) INSULATION blocking access to upper and lower COLLECTION HEADERS (see Figure 25 for an illustration of the LINK-SEAL surrounding the upper COLLECTION HEADER).

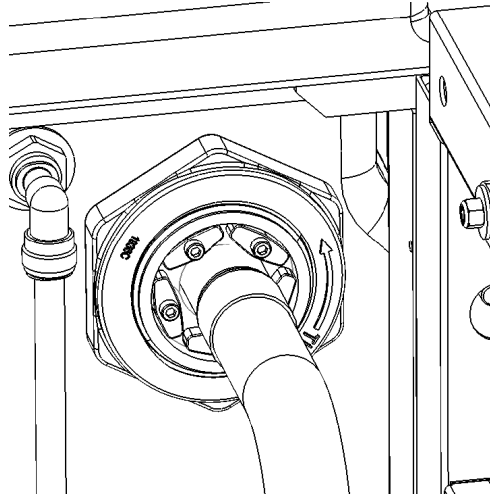

Figure 25 – Upper Link-Seal®

2. Use a 3/8” drive inch-pound torque wrench (with a 6” long 5/32” ball-point hex-bit socket) to tighten in even increments all LINK-SEAL SCREWS in the sequence shown in Figure 26. Starting point is not critical. Final torque should be 20 in-lb. DO NOT tighten more than four turns at a time.

NOTE: Be careful not to over torque the LINK-SEAL SCREWS.

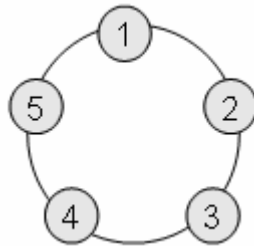

Figure 26 – Link-Seal Tightening Sequence

3. Reinstall INSULATION when done.

Electrical Connections

Power Service Requirements

| Model | System Type | Minimum Circuit Ampacity | Maximum Fuse |
|-----------|--------------------|--------------------------|--------------|
| IB30A-521 | 208/230V, 1 ϕ | 41.7 A | 50 A |
| IB30A-523 | 208/230V, 3 ϕ | 27.2 A | 30 A |
| IB30A-543 | 460V, 3 ϕ | 13.3 A | 20 A |

Refer to the electrical schematic located inside the unit's ELECTRICAL CONTROL BOX, or see the "resources" page at www.ice-energy.com. Note that electrical schematics are subject to change and do not reflect customizations performed by field technicians.

Service Disconnect Mounting on Unit

If your unit ICE BEAR UNIT includes a SERVICE DISCONNECT MOUNTING BRACKET, then mount the SERVICE DISCONNECT BOX on the ICE BEAR UNIT as follows (otherwise, refer to the following section, *Internal Service Disconnect Location*):

NOTE: Alternate wall or roof stand applications are permissible as per NEC and local codes.

1. The SERVICE DISCONNECT BOX MOUNTING BRACKET and accompanying HARDWARE and INSTRUCTIONS are shipped in the CONDENSING UNIT compartment of the ICE BEAR UNIT. Install MOUNTING BRACKET per the included instructions.
2. Mount SERVICE DISCONNECT BOX onto the MOUNTING BRACKET by drilling holes and fastening as necessary.
3. Feed wire and connect as appropriate in accordance with applicable electrical code. Refer to the electrical schematic located inside the unit's ELECTRICAL CONTROL BOX, or see the "resources" page at www.ice-energy.com. See the recommended routing of electrical CONDUIT in Figure 27 and Figure 28.

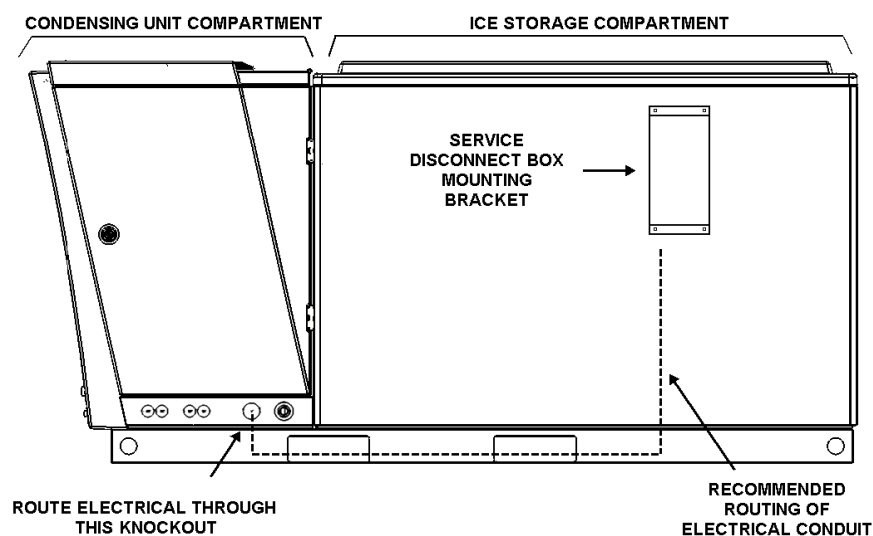

Figure 27 – Mounting Service Disconnect Box (Right Side)

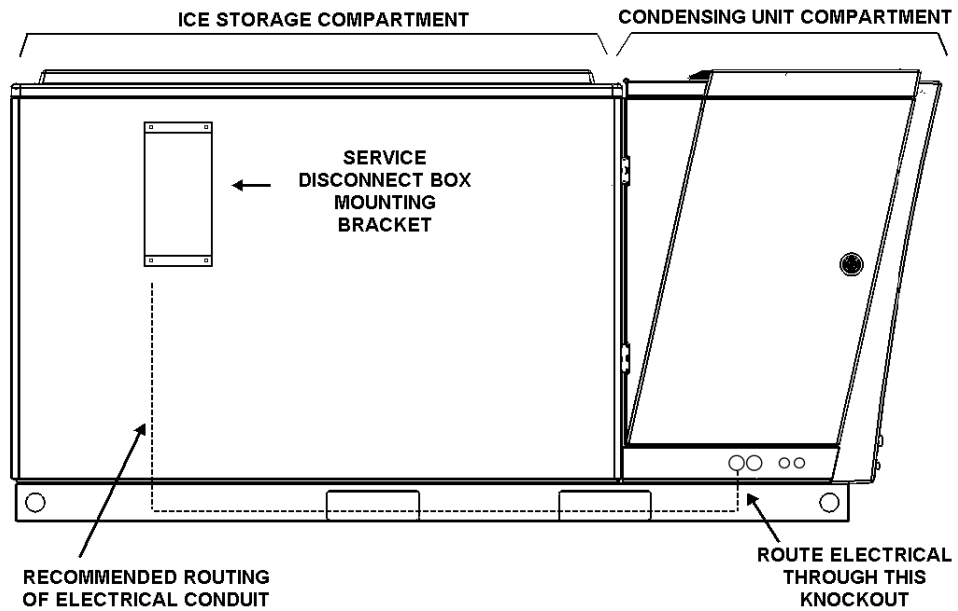

Figure 28 – Mounting Service Disconnect Box (Left Side)

Internal Service Disconnect Location

Note that on some ICE BEAR UNITS, the SERVICE DISCONNECT SWITCH is located in the ELECTRICAL CONTROL BOX and accessible via the right SERVICE ACCESS DOOR. See Figure 29.

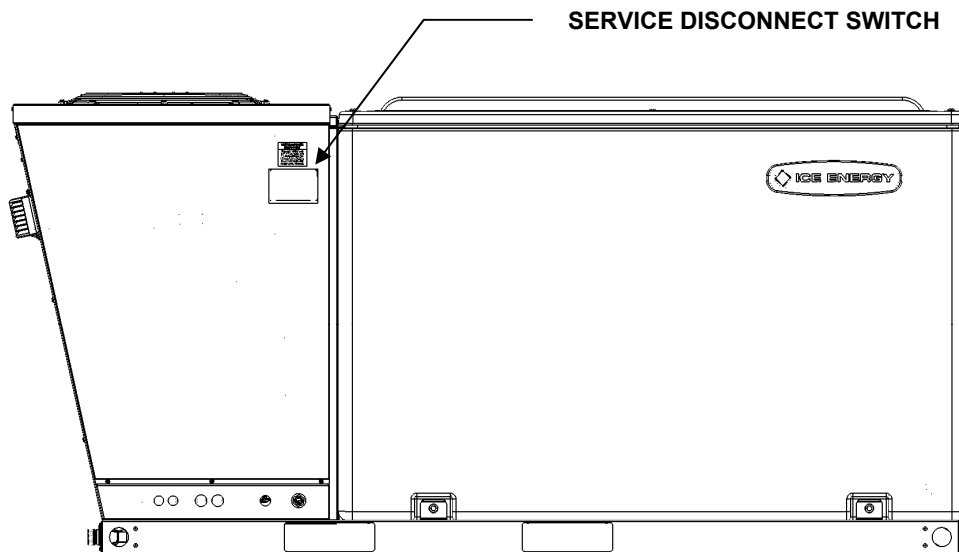

Figure 29 – Service Disconnect Switch

Line Power Connections

- All electrical wiring must comply with state and local electrical code requirements, as well as the NEC ANSI/NFPA 70, as amended.
- Use only copper conductors.

Grounding



WARNING

The ICE BEAR UNIT must have an uninterrupted electrical ground to minimize the possibility of personal injury if an electrical fault should occur, in accordance with NEC National Electrical Code (NEC), ANSI/NFPA 70 (as amended), and local electrical codes. Failure to adhere to this warning could result in personal injury or death.

Refer to the electrical schematic located inside the unit's ELECTRICAL CONTROL BOX, or see the "resources" page at www.ice-energy.com.

CoolData® Controller Connections

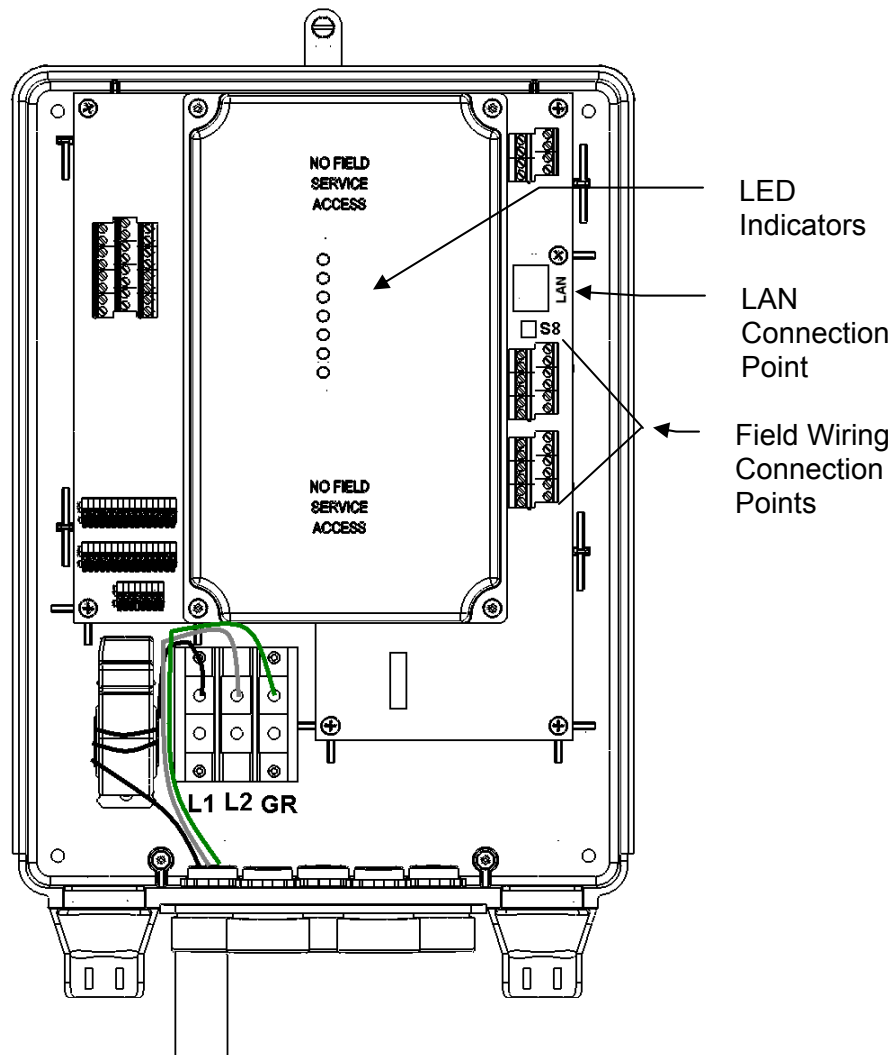

Figure 30 – CoolData® Controller Components

Minimum Requirements for Connection of CoolData Controller Wiring

The below items are the minimum requirements for basic common installations. Depending on the scope of a given installation, additional wiring may be required. Consult plans and engineering drawings to determine actual requirements. Contact Ice Energy Product Services (call 877-542-3232 or email productservices@ice-energy.com) if you have questions.

- Conform to engineering layout drawings showing locations of wiring and thermostat.
- Document deviations in the Ice Bear® 30 System Commissioning Report (F155-F160).
- Use one #18AWG insulated 8 conductor cable between ICE BEAR UNIT and each base system (e.g., air handler, packaged unit, ductless Ice-Coil) for control only.

- Use one #18AWG insulated (minimum 4 conductor) cable per CURRENT TRANSDUCER and one unshielded (UTP) CAT5e cable between each monitored base system and the ICE BEAR UNIT for monitoring only.
- If an alternate data service connection is required, use one CAT5e cable between the ICE BEAR UNIT and the alternate data service (Internet) location.
- Refer to the CoolData® electrical schematic located inside the CoolData CONTROLLER BOX, or see the “resources” page at www.ice-energy.com.

Controller Program and Configuration File

The ICE BEAR 30 UNIT includes multiple software-related components, including:

- Controller program—controls the overall system operation and communication. If an Internet connection is available, the Ice Bear unit will automatically connect to the Ice Energy server and check for program updates.
- Configuration files—define the specific configuration for a given unit, including parameters for date/time as well as charging/cooling time periods used to optimize the product with regard to utility rates. The configuration file also includes sensor setup information. Configuration Web pages provide a way to facilitate entry and modification of settings.

Currently, you must contact Ice Energy Product Services (call 877-542-3232 or email productservices@ice-energy.com) to ensure that your system has the appropriate software components based on your specific installation.

Post Installation

Installation Checklist

The following is a typical project checklist for reference purposes only. It is not intended to be all inclusive.

| Item | | Description |
|-------------|--------------------------|--|
| 1. | <input type="checkbox"/> | Secure required permits for project. |
| 2. | <input type="checkbox"/> | All components, tools, & equipment received and ready. |
| 3. | <input type="checkbox"/> | Site preparations completed. |
| 4. | <input type="checkbox"/> | ICE BEAR UNIT placed and unpacked. |
| 5. | <input type="checkbox"/> | New line sets installed, leak tested, & insulated. Are ICE-COIL supply and return lines insulated? |
| 6. | <input type="checkbox"/> | Evacuation of refrigerant on Ice Cooling side of system. |
| 7. | <input type="checkbox"/> | Release ICE BEAR UNIT Refrigerant Charge. |
| 8. | <input type="checkbox"/> | Finish roofing, as applicable (prior to filling TANK). |
| 9. | <input type="checkbox"/> | Fill TANK with water, add biocide, check LINK-SEALS. |
| 10. | <input type="checkbox"/> | Electrical power connections made. |
| 11. | <input type="checkbox"/> | Thermostat wiring connections made. |
| 12. | <input type="checkbox"/> | Secure lids & doors |
| 13. | <input type="checkbox"/> | Site clean-up & removal of materials |
| 14. | <input type="checkbox"/> | Complete Ice Bear 30 System Commissioning Report (F155-F160). |
| 15. | <input type="checkbox"/> | Ensure SERVICE SWITCH is in the “AUTO” position. |
| 16. | <input type="checkbox"/> | Outstanding field issues: |

Monitoring

If applicable, the following monitoring related tasks should be performed.

| Item | | Description |
|------|--------------------------|--|
| 1. | <input type="checkbox"/> | Confirmed Internet connection with provider (ISP or customer). |
| 2. | <input type="checkbox"/> | All SENSORS mounted and installed. |
| 3. | <input type="checkbox"/> | CoolData [®] CONTROLLER configured to include additional sensors. |
| 4. | <input type="checkbox"/> | Verified all sensor readings. |
| 5. | <input type="checkbox"/> | Verified CoolData connectivity with Ice Energy office. |
| 6. | <input type="checkbox"/> | Completed Ice Bear [®] 30 System Commissioning Report (F155-F160) |
| 7. | <input type="checkbox"/> | Posted completed Monitoring Information form on Ice-Gate. |

NOTE: All installation details and system modifications must be accurately and completely documented in the project Ice Bear[®] 30 System Commissioning Report (F155-F160). Include data gathered from the testing of Ice Make and Ice Cooling modes.

Service Switch

The SERVICE SWITCH allows a technician to switch modes for the purpose of servicing the unit (see Figure 2 for general location). The SERVICE SWITCH (two variations, represented in Figure 31 and Figure 32) provides three service modes:

- **BYPASS MODE** – allows the cooling signal to go directly to the existing/base equipment (thereby bypassing the ICE BEAR UNIT).
- **AUTO MODE** – allows the cooling signal to go directly to the ICE BEAR UNIT’s CoolData[®] CONTROLLER. The CoolData CONTROLLER then decides the appropriate course of action (based on time, ice availability, and on-board programming). AUTO MODE is the normal operation mode for the system.
- **OFF** – **Warning: This mode does not disable line voltage.** This mode only disables cooling control signals going through the CoolData CONTROLLER. All other functions will continue to operate. Follow approved servicing & maintenance procedures for all equipment; i.e., lockout/tagout procedures.

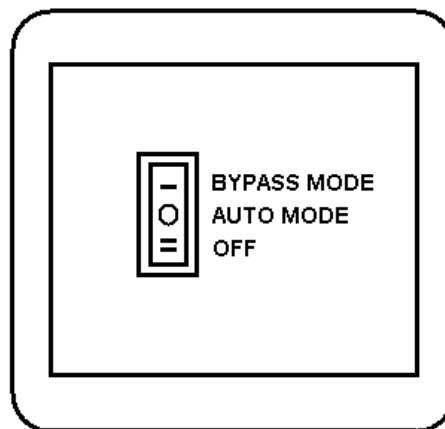

Figure 31 – Service Switch

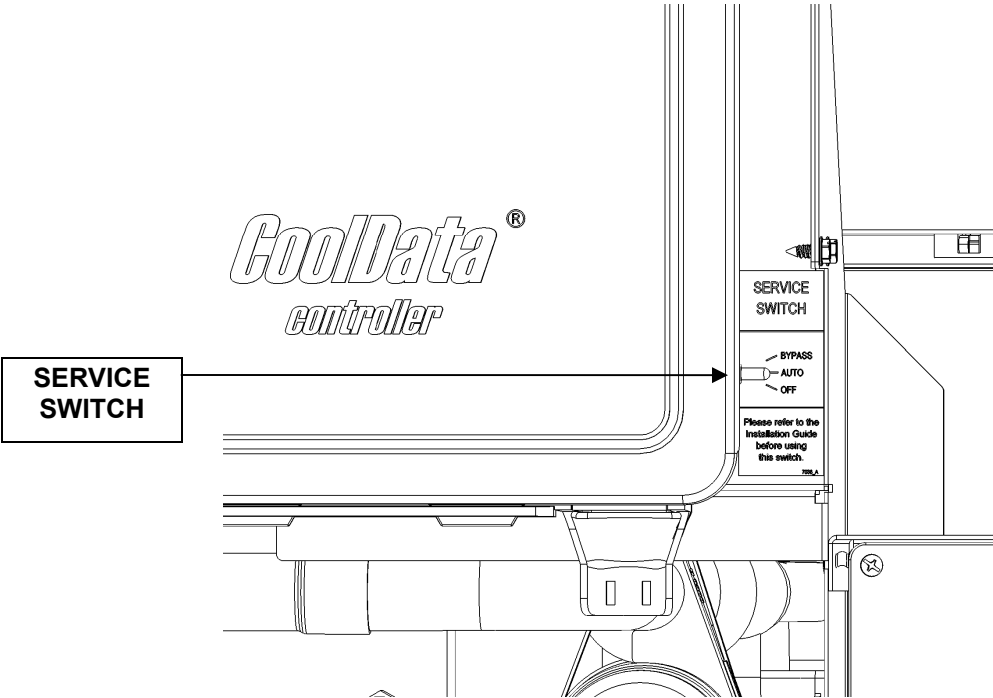

Figure 32 – New Service Switch & Location

System Startup & Verification

Sequence of Operation

The ICE BEAR UNIT is thermostatically controlled in the same manner as a conventional DX system. The controller for the ICE BEAR UNIT regulates the refrigerant and the UNIT's internal components similarly to a conventional DX air conditioning system. When a packaged unit is equipped with an economizer, the economizer and the HVAC system will operate normally in collaboration with the ICE BEAR UNIT.

The ICE BEAR UNIT's programmable controller responds to a single- or two-stage thermostat input. Either configuration allows the ICE BEAR UNIT to control the base system (allowing DX cooling during Ice Make, for example). With a two-stage input, the ICE BEAR UNIT and the additional system may be set up to provide cooling simultaneously; whereas, with a single-stage input, only one system will provide cooling at any given time. A single stage DX system connected to an ICE BEAR UNIT is referred to as the backup system. In a two-stage DX system with matching thermostat, the second DX system is referred to as a parallel system. The programming for the ICE BEAR UNIT's internal controller is based on the desired Ice Make and Ice Cooling operations. The ICE BEAR UNIT can be configured to provide Ice Cooling for any period of time consistent with the maximum cooling capacity, tank charge capacity, and tank recharge requirements. The desired operating schedules are set prior to shipment or by a certified installer in the field and can, if required, be reprogrammed remotely for optimization purposes.

The ICE BEAR UNIT integrates with facility control systems and simple thermostats through traditional 24VAC signals, both for control and status feedback. No other communications to a facility management system are required. The ICE BEAR UNIT is unique as an energy storage device in that it is a fully packaged, self-contained system. As such, it optimizes its performance independently of a facility management system. Integration for Supervisory Control and Data Access (SCADA), additional monitoring, and other advanced features are viable, but are not part of the standard offering.

For California Title 24 compliance applications, the programming is unalterable and operates within the parameters of the specified product model. Control parameters are given at the factory.

Charging (Ice Make Mode)

Startup Sequence

1. FAN #1 starts and the ELECTRONIC EXPANSION VALVE (EEV) is reset. (Charging LED blinks once.)
2. There is a 4 second delay.
3. FAN #2 starts.
4. Initial EEV position is set.
5. There is a 26 second delay.
6. Superheat set point is derived from the CONDENSER liquid temperature.
7. COMPRESSOR starts. (Charging LED blinks 3 times).
8. There is a 10 second delay.
9. EEV will start to control the system. (Charging LED is on solid.)

Full Charge Cutoff Sequence

1. Upon reaching charge cutoff pressure (typically 98.5 psia), the charging operation shuts down after 5 minutes.
2. The EEV is set to the closed position.

Cooling (Ice Cooling Mode)

Startup Sequence (call for cooling)

1. REFRIGERANT PUMP and SOLENOID VALVE are energized and WATER PUMP starts.
2. REFRIGERANT PUMP is initially set to minimum speed. (Cooling LED repeatedly blinks twice.)
3. There is a 10 second delay.
4. REFRIGERANT PUMP is set to its final speed. (Cooling LED on solid until call for cooling ends, ice is exhausted, or system transitions out of the configured ice cooling time window, as determined by unit's specific configuration.)

Shutdown Sequence (no call for cooling)

1. WATER and REFRIGERANT PUMPS shut down.
2. There is a 15 second delay.
3. Individual zone relay is closed.

Full Discharge Cutoff Sequence

1. Discharge cutoff condition is achieved; i.e., cutoff pressure is reached (typically 165 psia) or the Tank water reaches a temperature of 48 °F (typical).
2. There is a 5 minute delay.
3. REFRIGERANT and WATER PUMPS are shut down.
4. There is a 15 second delay.
5. Individual zone relays are closed, if defined.

Pre-startup Safety Warnings

Failure to observe the following warnings could result in serious personal injury.

WARNING

1. Follow recognized safety practices and wear protective eyewear when checking or servicing refrigerant system.
2. Do not operate the COMPRESSOR or provide any electrical power to the unit unless the COMPRESSOR TERMINAL COVER is in place and secured.
3. Do not remove the COMPRESSOR TERMINAL COVER until all electrical sources are disconnected.
4. Relieve all pressure from the system before touching or disturbing anything inside the COMPRESSOR TERMINAL BOX if a refrigerant leak is suspected near the COMPRESSOR TERMINALS.
5. Never attempt to repair a soldered connection while the refrigerant system is under pressure.
6. Do not use a torch to remove any component. The system contains oil and refrigerant under pressure. To remove a component, wear protective eyewear and proceed as follows:
 - a. Shut off electrical power to the unit. Install lockout tag.
 - b. Relieve all pressure from the system using both high-pressure and low-pressure ports.
 - c. Cut the component connection tubing with a tubing cutter, and remove the component from the unit.
 - d. Carefully unsweat the remaining tubing stubs when necessary. Oil can ignite when exposed to torch flame.

Pre-startup

Proceed as follows to inspect and prepare the unit for initial startup.

1. Open all access DOORS.
2. Verify that the voltage supplied is the same as the unit's nameplate rating.
3. Read and follow instructions on all WARNING, CAUTION, and informational labels attached to, or shipped with, the ICE BEAR UNIT.
4. Remove COMPRESSOR STABILIZATION PANEL from under COMPRESSOR (loosen BOLTS, remove C WASHERS, remove PANEL from under COMPRESSOR, and retighten BOLTS).
5. Make the following inspections:
 - a. Inspect for shipping and handling damage such as broken lines, loose parts, or disconnected wires, etc.
 - b. Inspect for oil at all refrigerant TUBING connections and on ICE BEAR UNIT BASE. Detecting oil generally indicates a refrigerant leak. Leak test all refrigerant TUBING connections using an electronic leak detector or liquid soap solution.
 - c. Inspect all field wiring and factory wiring connections. Ensure that connections are completed and tight.

- d. Inspect COIL FINS. If damaged during shipping and handling, carefully straighten the FINS with a fin comb.
6. Verify that all tools and loose parts have been removed.

Startup

Unit Preparation

Ensure that unit has been installed in accordance with these installation instructions and applicable codes. Be sure to complete the pre-startup checklist in the *Ice Bear® 30 System Commissioning Report* (F155-F160).

Refrigerant Service Ports

To access refrigerant SERVICE PORTS, open COMPRESSOR ACCESS DOOR (see Figure 3). The system has three Schrader-type SERVICE GAUGE PORTS: one on the SUCTION LINE, one on the LIQUID LINE, and one on the COMPRESSOR DISCHARGE LINE. Ensure that CAPS on the PORTS are tight.

NOTE: COMPRESSOR side and TANK side are factory charged.

Compressor Rotation

On three-phase ICE BEAR UNITS with scroll COMPRESSORS, it is important to be certain that COMPRESSOR is rotating in the proper direction. To determine whether or not COMPRESSOR is rotating in the proper direction:

1. Connect service gauges to suction and discharge pressure fittings.
2. Before powering up the unit, ensure that the SERVICE SWITCH is in Bypass Mode.
3. Energize the COMPRESSOR by attaching a JUMPER from pin 7 to pin 1, 2, 3, or 4 on the digital input connector. After verification, remove JUMPER.

NOTE: CONDENSER FANS will run 30 seconds before COMPRESSOR engages.

4. The suction pressure should drop and the discharge pressure should rise, as is normal on any startup.

If the suction pressure does not drop and the discharge pressure does not rise to normal levels:

1. Turn off power to unit and install lockout tag.
2. Reverse any two of the unit POWER LEADS.
3. Reapply power to unit. Reenergize COMPRESSOR.

The suction and discharge pressure levels should now move to their normal startup levels.

NOTE: When the COMPRESSOR is rotating in the wrong direction, the unit will make an elevated level of noise and the REFRIGERATION MANAGEMENT SYSTEM will fail to operate.

Final Startup Steps

1. Install additional monitoring SENSORS (e.g., supply & return air temperature, air handler work, building power, cooled area temperature).
2. Update configuration file to include monitoring SENSORS (contact Ice Energy Product Services for assistance).
3. Load configuration file (contact Ice Energy Product Services for assistance).
4. Set SERVICE SWITCH to Auto Mode.

See *CoolData Controller LED Codes* section below.

CoolData[®] Controller LEDs

Reference the following information for CoolData CONTROLLER LED descriptions:

| LED | Description |
|--------------|---|
| POWER | Lit when power is supplied to the CoolData CONTROLLER. |
| STATUS | Blinks when indicating the current system status. This LED will not indicate error status (see following section, <i>CoolData Controller LED Codes</i>). |
| CHARGING | Blinks if the system is in the process of making ice. This may include delays where no activity is apparent. |
| COOLING | Blinks if the system is in the process of providing cooling by melting ice. This may include delays where no activity is apparent.. |
| ERROR | Blinks to indicate the current error code (see following section, <i>CoolData Controller LED Codes</i>). |
| LAN CONNECT | Lit if the ICE BEAR UNIT is connected to a Local Area Network (LAN). |
| LAN ACTIVITY | Blinks if network activity is present. |

CoolData Controller LED Codes

| LED | Activity | Description |
|--------------------------|----------|--|
| STATUS | 1 blink | Idle |
| | 2 blinks | ICE BEAR UNIT active, backup system inactive (Ice Make / Ice Cooling state determined by other LEDs) |
| | 3 blinks | ICE BEAR UNIT may be active, backup system is active (Ice Make / Ice Cooling state determined by other LEDs) |
| CHARGING (ICE MAKE) | Off | Idle |
| | 1 blink | COMPRESSOR short cycle delay (5 min) or Charging delay (based on estimated charging time). Temperature is determined during final 30 seconds of delay. |
| | 3 blinks | Startup control delay of 10 seconds |
| | On | Actively Charging |
| COOLING (ICE COOLING) | Off | Idle |
| | 1 blink | SOLENOID VALVE open delay |
| | 2 blinks | REFRIGERANT PUMP running at minimum output for 10 seconds |
| | On | Actively providing Ice Cooling. REFRIGERANT PUMP runs at configured output. |
| ERROR | 1 blink | Ice Make not allowed |
| | 2 blinks | Ice Cooling not allowed |
| | 3 blinks | Ice Make and Ice Cooling not allowed |
| | 4 blinks | Bypass active |
| | 5 blinks | System disabled |

Software Verification

Confirm that the CoolData® CONTROLLER software program version matches the software configuration associated with the unit's model number (TDV units only).

- The proper operating program should already be loaded into the ICE BEAR UNIT's programmable CoolData CONTROLLER (TDV units only).
- Contact Ice Energy Product Services to verify the latest revision of the CoolData® CONTROLLER software.

CAUTION

Keep in mind that time delays may exist in the CoolData® CONTROLLER program and the COMPRESSOR control circuit.

CAUTION

During the verification process, the installer must closely observe the charging manifold gauges for signs of abnormal operating conditions.

WARNING

In the case of inclement weather or high winds, to prevent damage and/or injury, secure the TANK LID, FAN LID ASSEMBLY, and UNIT DOORS.

Maintenance

General Maintenance

Ice-Coil

Follow industry standards for service and maintenance of EVAPORATOR COILS.

Condensate Drain

Check and clean each year at the start of cooling season. In winter, keep drain dry or protect against freeze-up.

Condenser Coil

Keep CONDENSER COIL fins clean and inside of CONDENSER free of debris, following standard practices.

Maintaining Adequate Water Level

Inspect water level annually. If necessary, fill ICE BEAR UNIT STORAGE TANK with tap water to the bottom of the top PIPE shown in Figure 24.

Periodic Maintenance

When performing a service call on an ICE BEAR UNIT, use each of the following lists as reminders on what to check.

| Interval | Maintenance Required |
|---|---|
| During each service/maintenance call, or at a minimum, annually | Verify CoolData® CONTROLLER program, including time/date (daylight savings, if applicable). |
| | Cycle all applicable modes of operation (Ice Make, Ice Cooling). |
| | Verify operating pressures (during Ice Make). |
| Annually | Check electrical connections. |
| | Check and record Amp draws of ICE BEAR 30 UNIT and corresponding DX UNIT. |
| | Visually inspect FAN BLADES. |
| | Visually inspect overall system (look for leaks, inspect FAN BLADES, inspect INSULATION & PIPING, etc.). |
| | Check operation of REFRIGERANT PUMP and WATER PUMP. |
| | Check water level in TANK; top off water level if necessary to the bottom of top PIPE, shown in Figure 24. |
| | Add water treatment. Suggested biocides: <ul style="list-style-type: none"> • MB-10® (Quip Laboratories Inc.) – two (2) 6 gram tablets • #90 Algaecide (Nu-Calgon) – two (2) tablets for clean water; five (5) tablets for fouled water |
| As needed | Oil CONDENSER FAN MOTOR BEARINGS, if applicable. |
| | Clean CONDENSER COIL. |

Low Ambient Operation

The ICE BEAR UNIT's ICE STORAGE TANK is insulated to prevent excessive system freezing. The ICE BEAR UNIT also includes an automatic control feature that periodically circulates water to help prevent freezing in water distribution components.

Water Pump Cycling

Based on CABINET temperature (CBt), the ICE BEAR UNIT's WATER PUMP will cycle (for a 20 minute period) for freeze protection as follows:

- Runs 5% duty cycle at 33/35 °F ambient
- Runs 20% duty cycle at 30/33 °F ambient
- Runs 50% duty cycle at 27/30 °F ambient
- Runs 75% duty cycle at 24/27 °F ambient
- Runs 100% duty cycle at 21/24 °F ambient

The cycle will repeat, as necessary, based on measured CABINET temperature.

If the above parameters are incompatible with your region, or your unit requires an extended shutdown period, contact productservices@ice-energy.com.

Fan Cycling

During low ambient temperatures, the ICE BEAR UNIT's two FANS will cycle as follows based on CONDENSER liquid temperature (CLt):

- FAN #1 (on left when facing CONDENSER)
 - Off if CLt < 45 °F
 - On if CLt > 67 °F and FAN2 has been on for 3 min
- FAN #2 (on right when facing CONDENSER)
 - Off if CLt < 45 °F and FAN1 has been off for 5 min
 - On if CLt > 63 °F

Appendix A – Product Specifications

Ice Bear® Unit Physical Properties

| | |
|---|-----------------------------|
| Dimensions (W x D x H) | 100-1/2" x 61" x 49" |
| Weight (without water) | 1,550 lb |
| Weight (filled) | 5,550 lb |
| Load distribution (filled) | 156 lb per ft ² |
| Water Volume | 475 gallons |
| Refrigerant Charge, TANK (Ice Cooling) | 35 lb R-410A (factory) |
| Refrigerant Charge, COMPRESSOR (Ice Make) | 11 lb 8 oz R-410A (factory) |

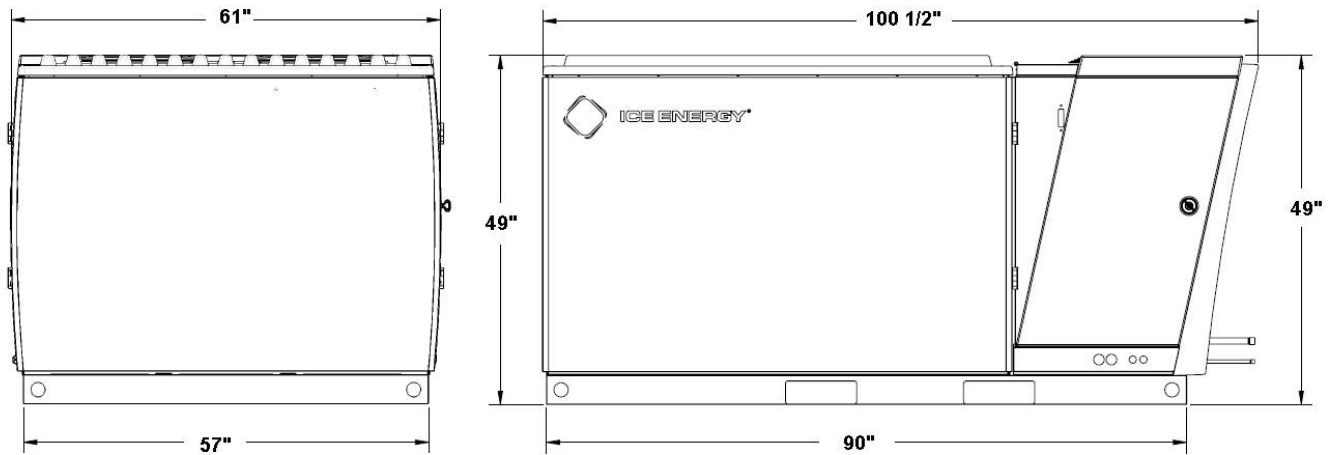

Figure 33 – Ice Bear® Unit Rear & Side Views

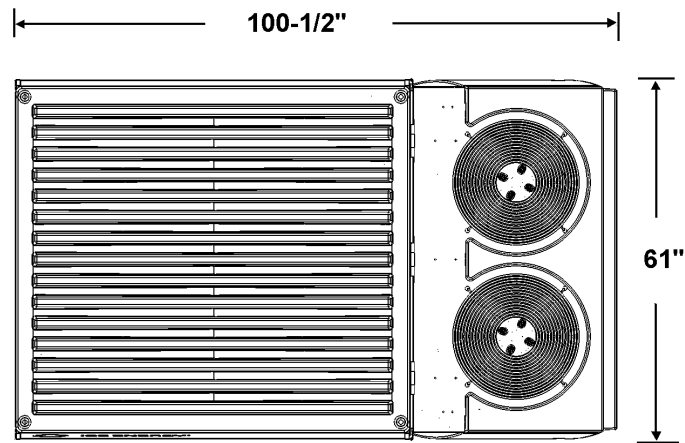

Figure 34 – Ice Bear® Unit Top View

See the below figures for dry center of gravity.

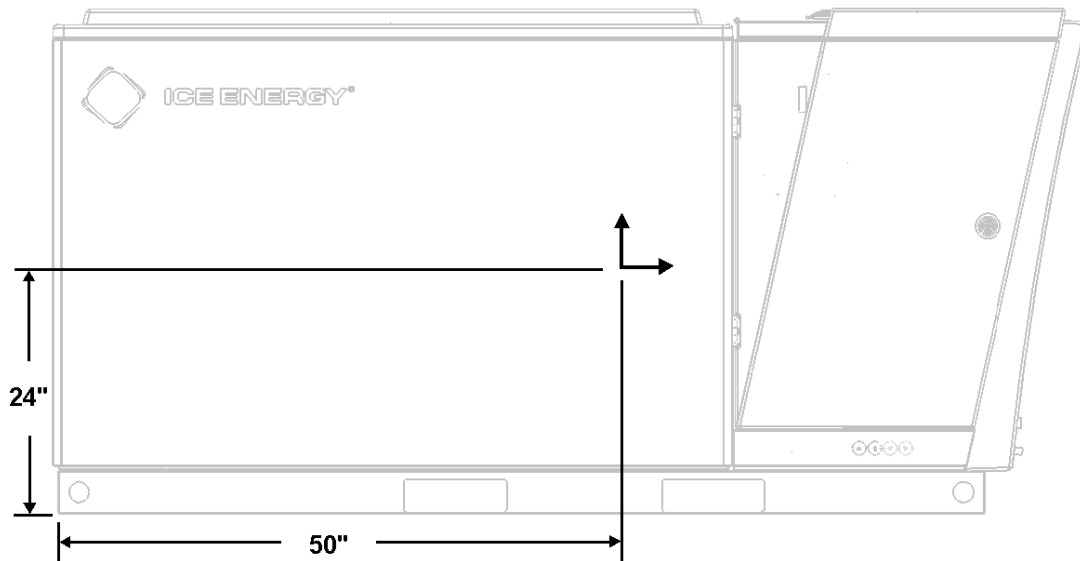

Figure 35 – Ice Bear® 30 Unit Dry Center of Gravity (Left)

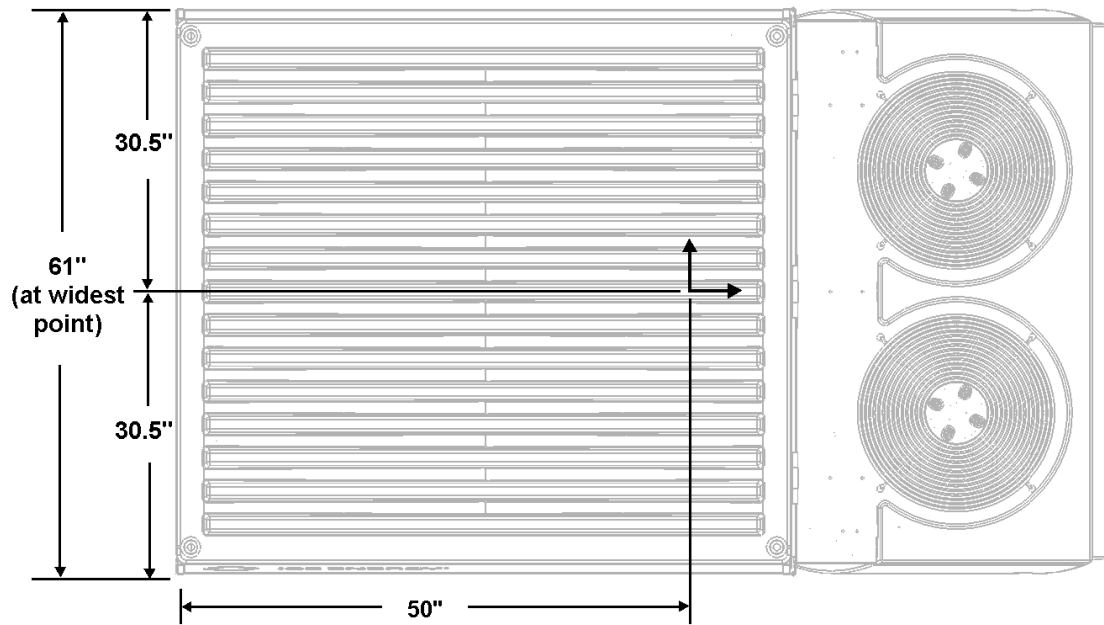

Figure 36 – Ice Bear® 30 Unit Dry Center of Gravity (Top)

See the below figures for wet (water-filled) center of gravity.

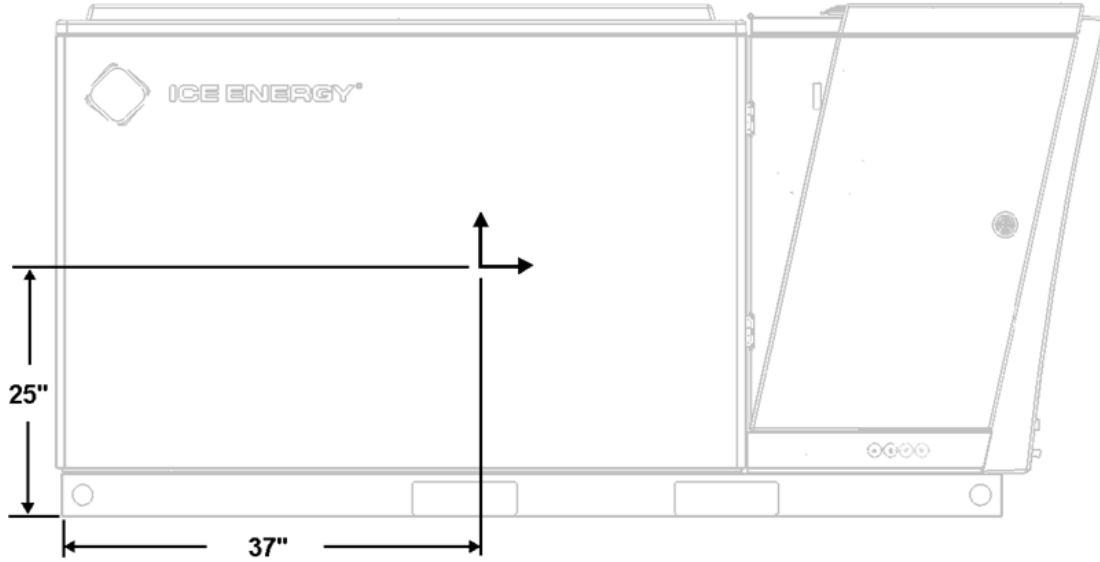

Figure 37 – Ice Bear® 30 Unit Wet Center of Gravity (Left)

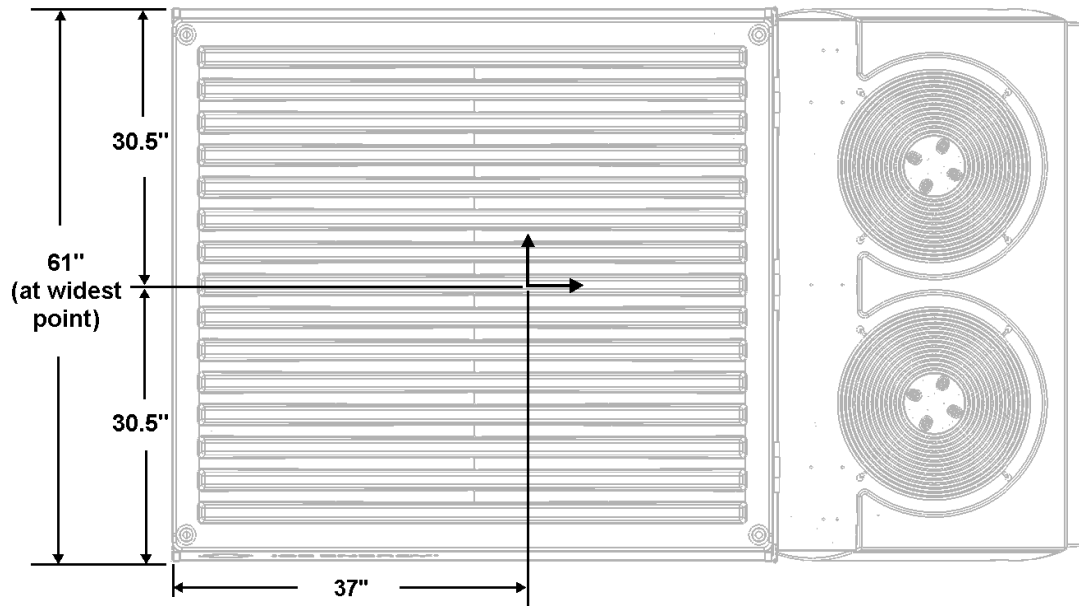

Figure 38 – Ice Bear® 30 Unit Wet Center of Gravity (Top)

Ice Energy, Inc.
9351 Eastman Park Dr., Suite B
Windsor, CO 80550
Phone: (877) 542-3232
(970) 545-3630
Fax: (970) 545-3634
Email: productservices@ice-energy.com
www.ice-energy.com

For parts or service, contact your Ice Energy representative.
