



ICE ENERGY®

INTELLIGENT STORAGE AT WORK.™

Ice Bear® 30 Unit

Operation & Maintenance

for models:

IB30A-521

IB30A-523

IB30A-543

through SN

xxxx10130

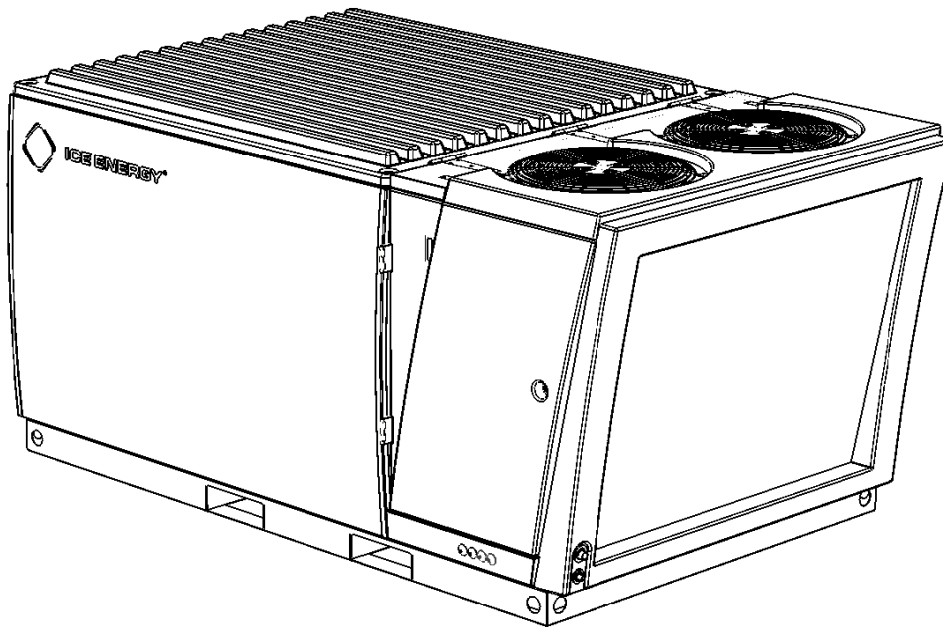

Phone: (877) 542-3232

Fax: (970) 545-3634

Email: productservices@ice-energy.com

www.ice-energy.com

Copyright, Notices, and Trademarks

© Ice Energy, Inc., 2009. All Rights Reserved.

No reproduction/distribution without permission.

While this information is presented in good faith and believed to be accurate, Ice Energy disclaims the implied warranties of merchantability and fitness for a particular purpose and makes no express warranties except as may be stated in its written agreement with and for its customers.

In no event is Ice Energy liable to anyone for any indirect, special or consequential damages. The information and specifications in this document are subject to change without notice.

Ice Energy, Ice Bear and CoolData are registered trademarks and Ice-Ready, Ice-Coil, and Hybrid Cooling are trademarks of Ice Energy, Inc. Other brand or product names are trademarks of their respective owners.

Table of Contents

Introduction.....	1
About this Guide.....	1
Definitions of Terms.....	1
Product Data and Specifications.....	2
Ice Bear [®] 30 Unit Components.....	3
Ice Bear Unit Modes of Operation.....	7
Ice Charging.....	7
Ice Cooling.....	7
Sequence of Operation.....	8
Charging (Ice Make).....	9
Cooling (Ice Melt).....	10
CoolData [®] Controller.....	11
CoolData Controller LEDs.....	11
CoolData Controller LED Codes.....	12
Service Switch.....	13
Troubleshooting Procedures.....	14
No Apparent Power to System.....	14
Ice Charging Mode (typical nighttime/off-peak operation).....	15
Ice Cooling (Ice Bear unit / Ice Bear unit and DX).....	19
Ice Cooling (cooling the conditioned space).....	21
Other Components.....	23
Ice-Coil Diagnostics.....	24
CoolData Programming.....	25
Appendix A – Ice Bear [®] 30 Unit Detailed Sequence of Operation.....	26
Ice Charging.....	26
Ice Cooling.....	27
Low Ambient Conditions.....	27
Appendix B – System Pressure & Temperature Thresholds.....	29
Appendix C – System Refrigerant Recovery, Evacuation & Charging Procedures.....	30
System Refrigerant Recovery.....	31
System Charging Procedures.....	36
Appendix D – Service & Maintenance Procedures.....	38
Link-Seal [®] Adjustments.....	38
Water Pump Service & Maintenance.....	39
Water Pump Replacement.....	41
Refrigerant Pump and Inverter Service.....	42

Table of Figures

Figure 1 – Ice Bear® 30 Unit Exterior Components 3
Figure 2 – Ice Bear® 30 Unit Internal Components 3
Figure 3 – Ice Bear® 30 Unit Internal Components (Left Side)..... 4
Figure 4 – CoolData® Controller 5
Figure 5 – Ice Bear® Unit Internal Components (Right Side)..... 6
Figure 6 – Electrical Control Box Fuse Locations..... 6
Figure 7 – Refrigerant Flow Schematic – Ice Charging Mode 7
Figure 8 – Refrigerant Flow Schematic – Ice Cooling Mode 8
Figure 9 – Ice Charging Active Components & Operating Sequence 9
Figure 10 – Ice Cooling Active Components & Operating Sequence 10
Figure 11 – CoolData® Controller LEDs Location 11
Figure 12 – Service Switch 13
Figure 13 – CoolData® Terminals..... 21
Figure 14 – Valve & Port Locations – Left Side 30
Figure 15 – Port Locations – Right Side..... 30
Figure 16 – Upper Link-Seal 38
Figure 17 – Link-Seal Tightening Sequence..... 38
Figure 18 – Water Hose Clamps & Pump Inlet Port..... 39
Figure 19 – Refrigerant Pump/Inverter Top & Side Covers 42
Figure 20 – Refrigerant Pump Inverter 43
Figure 21 – Refrigerant Pump & Inverter Assembly 44
Figure 22 – Inverter Bolts 45

List of Tables

Table 1. Ice Bear 30 Unit Cooling Performance..... 2
Table 2. Ice Bear 30 Unit Physical Properties 2
Table 3. Ice Bear 30 Unit Electrical Properties 2
Table 4. Pressure & Temperature Thresholds and Effects..... 29
Table 5. Altitude vs. Atmospheric Pressure..... 29

Introduction

The ICE BEAR® 30 unit is an off-the-shelf hybrid condensing unit for use with direct expansion air conditioning systems. The Ice Bear unit is designed to store energy at night and then shift the on-peak electrical energy of a condensing unit common to packaged rooftop, split, and mini-split systems. A typical application will shift the electrical energy consumed by a 5-Ton scroll compressor and its associated condensing unit fans operating under full load conditions, for 6 hours continuously. Electrically, the Ice Bear unit shifts approximately 30 kW-hours of energy to the off-peak, and reduces about 6 kW of electrical on-peak demand for six hours.

The Ice Bear unit runs its integral condensing unit for about 10 hours continuously, during the coolest part of the night, to store energy in the form of ice (30 latent ton-hours). The control signal from the thermostat or building management system is received by the Ice Bear unit's CoolData® controller. Based on the time-of-day, or upon a command to shed electrical demand initiated by the utility, the controller determines if the Ice Bear hybrid condensing unit or the electrically operated condensing unit will operate. In the case of the Ice Bear unit, it pumps enough oil-free R-410A refrigerant to an Ice-Coil evaporator to provide effective cooling for up to 5 tons of continuous load for six hours, using less than 300 watts of power. A unique and important design feature is the Ice Bear unit's cooling performance independent of outdoor ambient or rooftop temperature; in other words it can be 75 °F or 140 °F and the Ice Bear unit and its associated Ice-Coil's cooling performance (5 ton rating) is unchanged.

About this Guide

This Operation & Maintenance manual is intended to provide basic information to assist in the operation, maintenance, and troubleshooting of the Ice Bear system by persons with Ice Energy® factory training. This guide is not intended to provide comprehensive application and installation instructions nor replace factory training. Consult Ice Energy Product Services department for further information.

Call 877-542-3232 for 24 hour emergency service and technical support.

Definitions of Terms

Base System: A refrigerant based, direct expansion (DX) air conditioning system, commonly referred to as a packaged rooftop unit, split system, or mini-split system. A typical base system includes a condensing unit, an evaporator, a blower, and controls.

Ice-Coil™ Kit: An Ice-Coil and ancillary parts needed to convert a packaged rooftop unit into an Ice-Ready Rooftop Unit.

Ice-Coil™: A flooded evaporator coil provided by Ice Energy, or modified to Ice Energy's specifications. The Ice-Coil is dedicated to the Ice Bear unit and is sometimes referred to as a liquid overfeed evaporator coil.

Ice-Cooling: The process whereby the Ice Bear unit's stored ice cools the refrigerant used to provide cooling to a building space during peak energy hours (typically noon to 6pm).

Ice-Make: The nighttime process by which the Ice Bear unit converts its tank of water into a tank of ice to be used for cooling the next day during the peak energy hours (typically noon to 6pm).

Ice-Ready™ Rooftop Unit: A packaged rooftop unit modified to include an Ice-Coil.

Multi-Stage System: A packaged rooftop unit, typically greater than 5 tons, that includes multiple independent refrigeration circuits; for example, a 10-ton unit with two 5-ton circuits.

Peak Shifting: Shifting electric load from the utility defined on-peak period to the off-peak period. On-Peak hours are typically noon through 6 pm.

Redundant Coil: The addition of an Ice-Coil to a packaged rooftop unit or split system.

Residual Ice: Occurs when the CoolData controller processing indicates that ice has fully melted in the storage tank but there is still a substantial amount of remaining ice. Also used to describe instances where ice forms to the edges of the storage tank.

Summer Mode: The CoolData® controller’s programming is optimized to insure that stored cooling is available during peak energy hours.

Standard Circuit: A common DX refrigeration circuit that includes an evaporator coil, expansion device, and condensing unit.

Ton-hours: Capacity in tons times the number of hours (e.g., 5 tons for 6 hours = 30 ton-hours); an important design consideration for fixed capacity storage units such as the Ice Bear unit.

Winter Mode: The CoolData controller is programmed to extend the Ice Cooling hours to more fully utilize the stored cooling capacity of the unit.

Product Data and Specifications

Table 1. Ice Bear 30 Unit Cooling Performance

Maximum instantaneous cooling capacity	5 tons
Total storage module capacity	30 ton-hours
Maximum on-peak electrical demand (at maximum application parameters, excluding crankcase heater)	350 watts
Nominal on-peak electrical demand (typical installation)	300 watts
Ice Charging time (from fully melted tank of ice)	11.5 hours at 75 °F outdoor ambient temp.

Table 2. Ice Bear 30 Unit Physical Properties

Dimensions (W x D x H)	100-1/2" x 61" x 49"
Weight (without water)	1,550 lb
Weight (filled)	5,550 lb
Load distribution (filled)	204 lb/linear ft (156 lb. per ft ²)
Water volume	475 gallons
Refrigerant charge, tank (Ice Cooling)	35 lb R-410A (factory)
Refrigerant charge, compressor (Ice Charging)	11 lb 8 oz R-410A (factory)

Table 3. Ice Bear 30 Unit Electrical Properties

Model	System Type	Minimum Circuit Ampacity (MCA)	Maximum Fuse
IB30A-521	208/230V, 1 ϕ	41.7	50
IB30A-523	208/230V, 3 ϕ	27.2	30
IB30A-543	460V, 3 ϕ	13.3	20

Ice Bear® 30 Unit Components

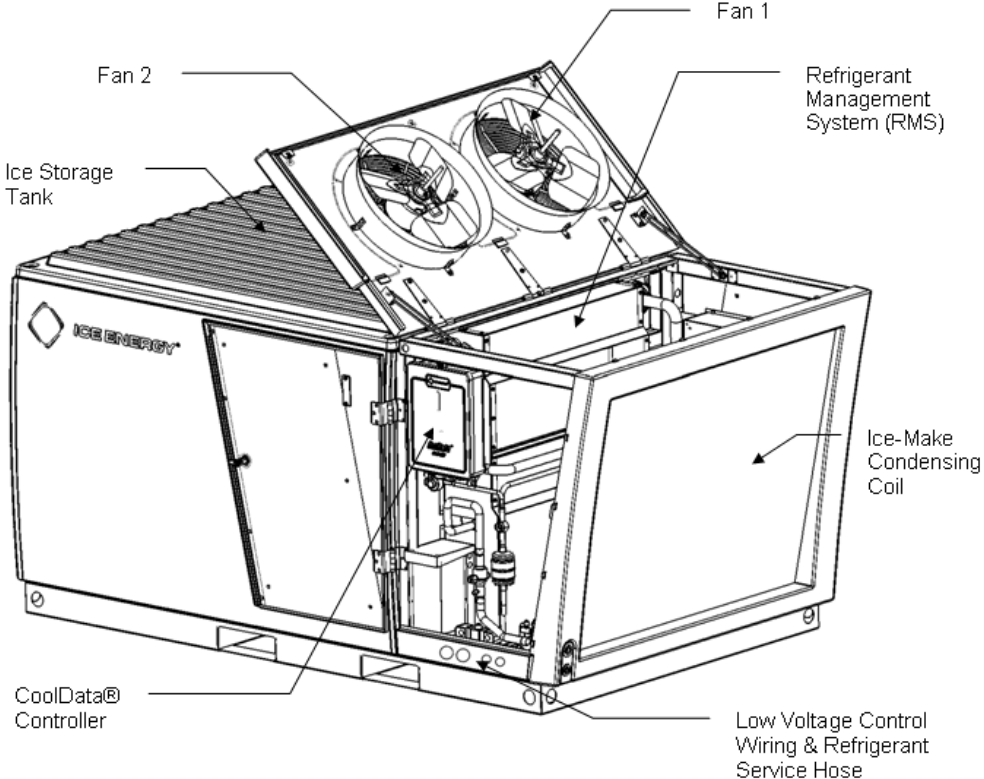

Figure 1 – Ice Bear® 30 Unit Exterior Components

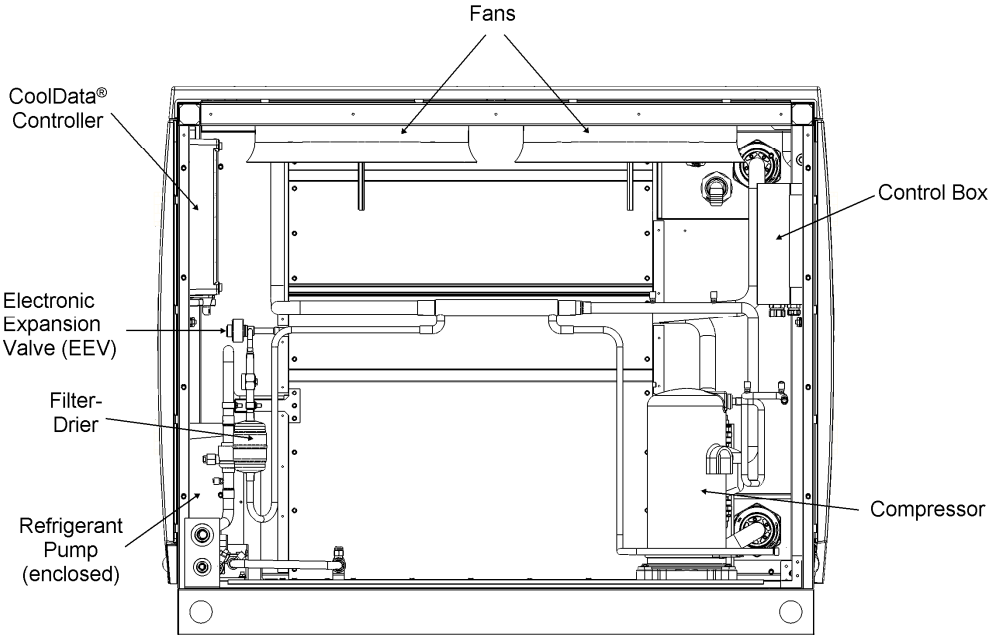

Figure 2 – Ice Bear® 30 Unit Internal Components (Front view, Condenser Coil not shown for clarity.)

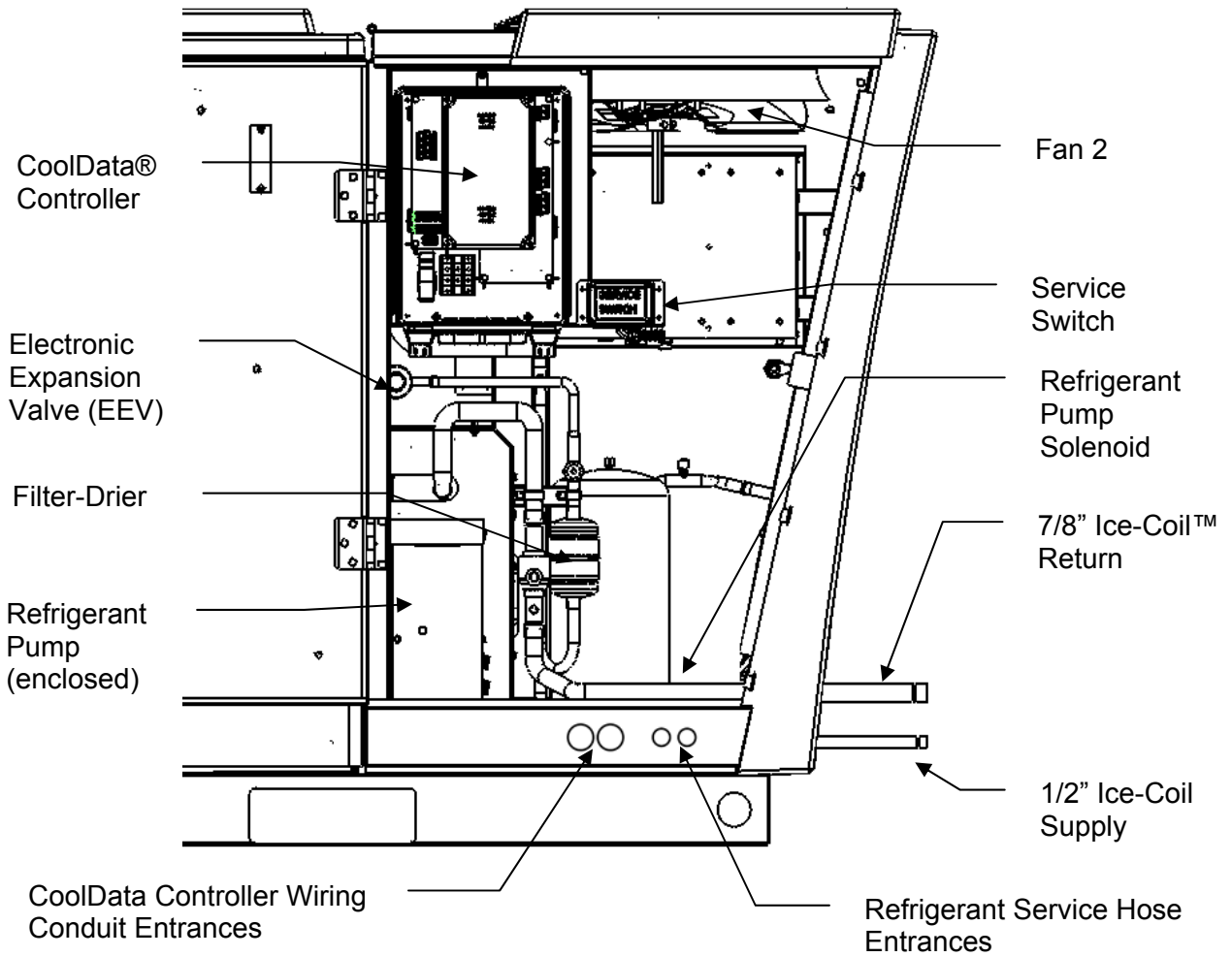

Figure 3 – Ice Bear® 30 Unit Internal Components (Left Side)

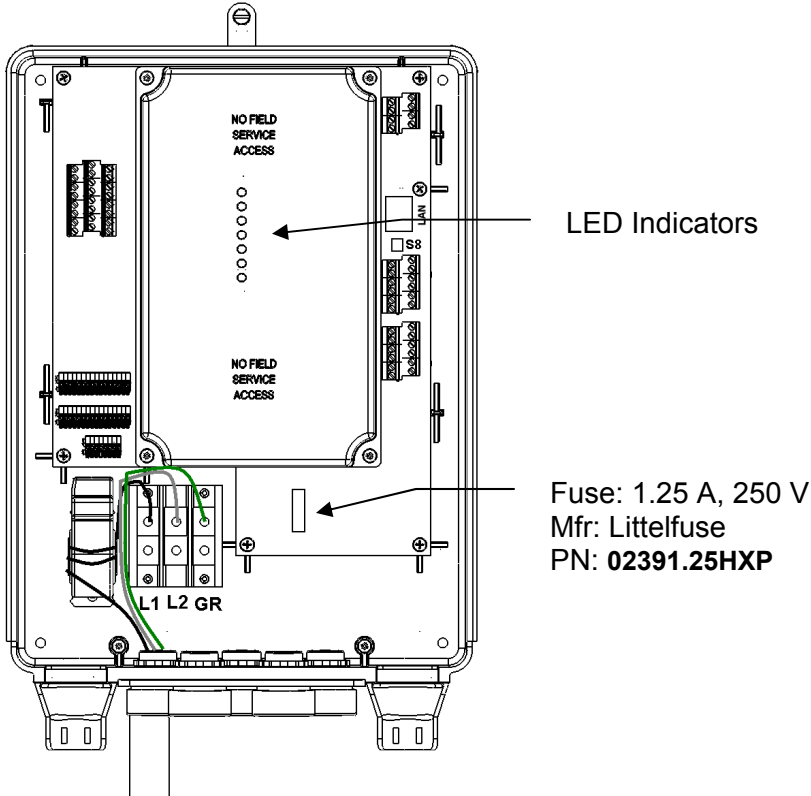

Figure 4 – CoolData® Controller

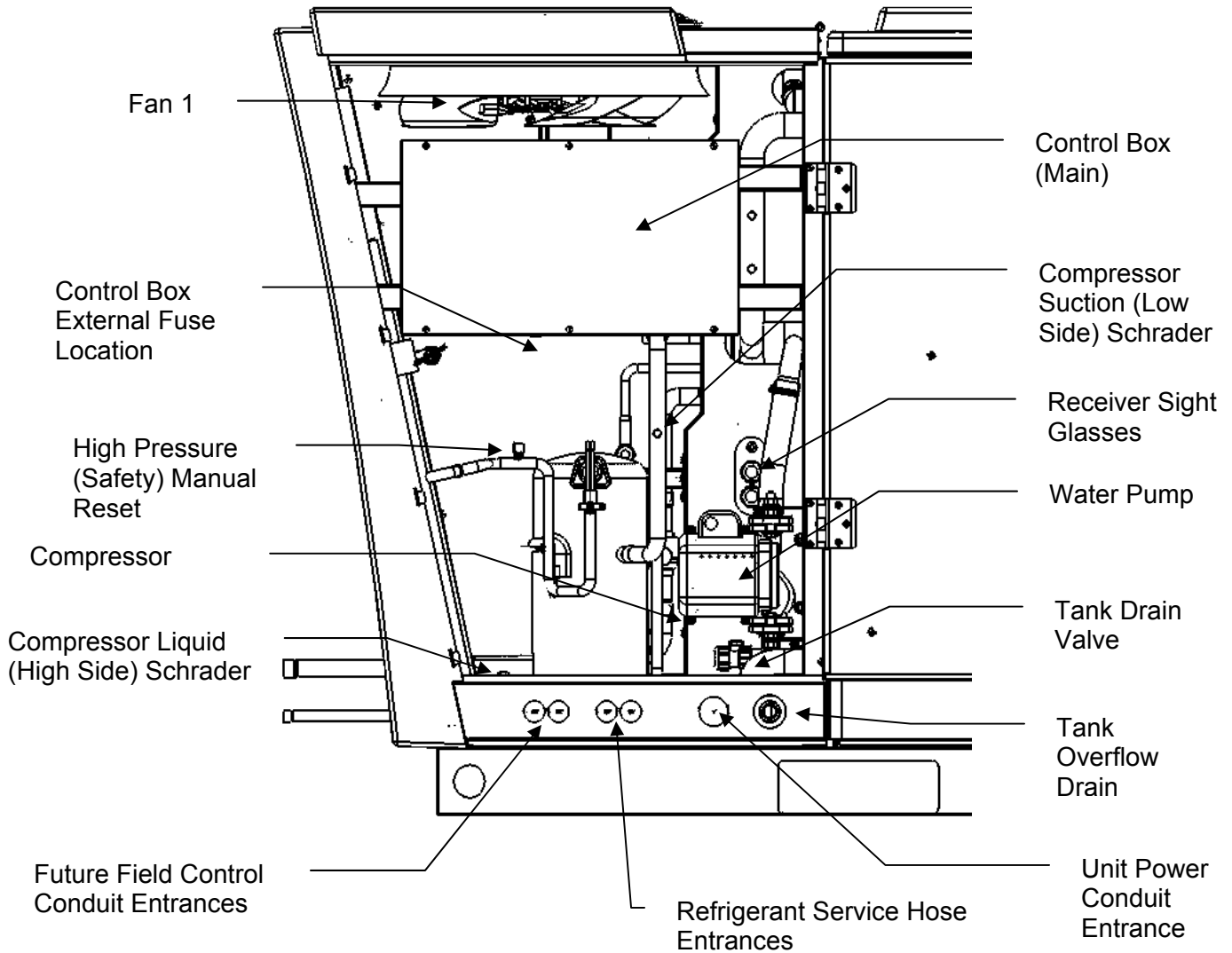

Figure 5 – Ice Bear® Unit Internal Components (Right Side)

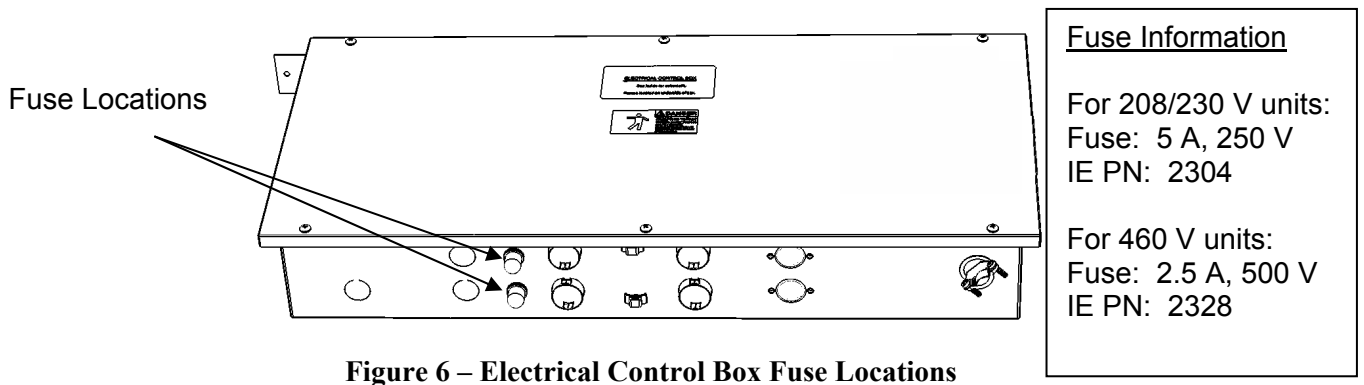

Figure 6 – Electrical Control Box Fuse Locations

Ice Bear Unit Modes of Operation

Ice Charging

During Ice Charging mode, the integral, factory pre-charged Ice Bear condensing unit (R-410A refrigerant and miscible oil) provides low temperature refrigerant to the Ice Bear unit's Refrigeration Management System (RMS). On the secondary side of the RMS, a separate, oil-free R-410A charge automatically circulates through a heat exchanger until the tap water freezes into a solid block of ice.. Note that ice does not form to the edge of the tank (i.e., it is normal for a water jacket to exist around the inside perimeter of the tank).

Ice Charging typically takes 10 hours for a full 30 ton-hour charge. Ice is made during the coolest time of night or when electrical utility rates are at their lowest or off-peak times.

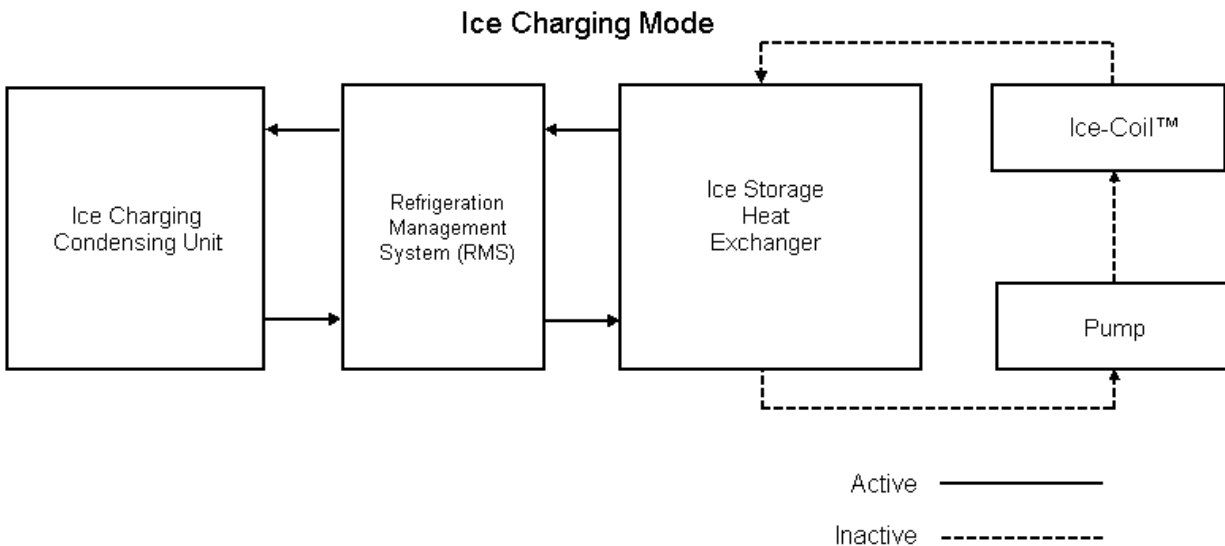

Figure 7 – Refrigerant Flow Schematic – Ice Charging Mode

Ice Cooling

During Ice Cooling mode, the integral Ice Bear condensing unit is switched off and typically one 5-ton condensing coil on the Base System is locked out. The Ice Cooling circuit, which includes an ice-on-coil heat exchanger, a refrigerant pump, and Ice-Coil™ are physically isolated from the Ice Charging circuit and its refrigerant charge by a unique receiver/separator. When there is a request for cooling, a refrigerant pump circulates the oil-free liquid R410-A refrigerant through the liquid supply line to a redundant Ice-Coil located in the air stream. Typically this is an Ice-Coil installed into a packaged rooftop unit or a slab coil mounted in the air supply duct. The vapor return line returns vaporized or mixed phase refrigerant to the Ice Bear unit's ice-on-coil heat exchanger where it melts ice and is condensed back into its liquid state.

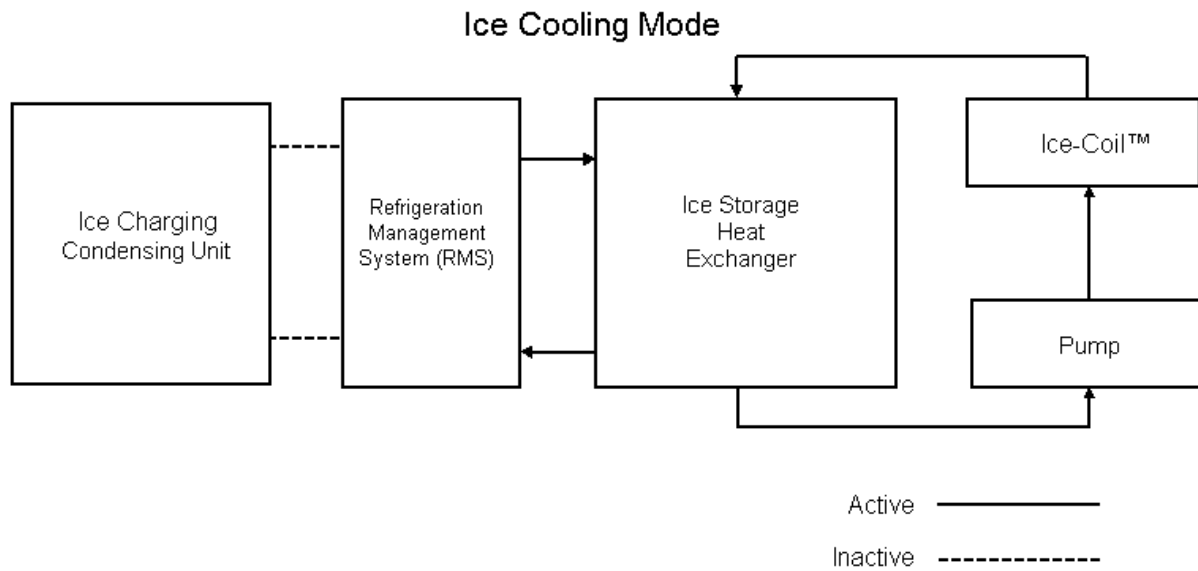

Figure 8 – Refrigerant Flow Schematic – Ice Cooling Mode

Sequence of Operation

The Ice Bear unit is thermostatically controlled in the same manner as a conventional DX system. The controller for the Ice Bear unit regulates the refrigerant and the unit's internal components similarly to a conventional DX air conditioning system. When a packaged rooftop unit is equipped with an economizer, the economizer and the HVAC system will operate normally in collaboration with the Ice Bear unit.

The Ice Bear unit's programmable controller responds to a single- or two-stage thermostat input. Either configuration allows the Ice Bear unit to control the base system (allowing DX cooling during Ice Charging, for example). With a two-stage input, the Ice Bear unit and the additional system may be set up to provide cooling simultaneously; whereas, with a single-stage input, only one system will provide cooling at any given time. A single stage DX system connected to an Ice Bear unit is referred to as the backup system. In a two-stage DX system with matching thermostat, the second DX system is referred to as a parallel system. The programming for the Ice Bear unit's internal controller is based on the desired Ice Charging and Ice Cooling operations. The Ice Bear unit can be configured to provide Ice Cooling for any period of time consistent with the maximum cooling capacity, tank charge capacity, and tank recharge requirements. The desired operating schedules are set prior to shipment or by a certified installer in the field and can, if required, be reprogrammed remotely for optimization purposes.

NOTE: The Charging start time may be delayed to utilize the lowest ambient temperature during Ice Charging. Actual Charging start time will be based on estimated remaining ice capacity.

The Ice Bear unit integrates with facility control systems and simple thermostats through traditional 24VAC signals, both for control and status feedback. No other communications to a facility management system are required. The Ice Bear unit is unique as an energy storage device in that it is a fully packaged, self-contained system. As such, it optimizes its performance independently of a facility management system.

For California Title 24 compliance applications, the programming is unalterable and operates within the parameters of the specified product model. Control parameters are given at the factory.

Charging (Ice Make)

The figure below assumes a CONDENSER cabinet temperature of at least 45°F.

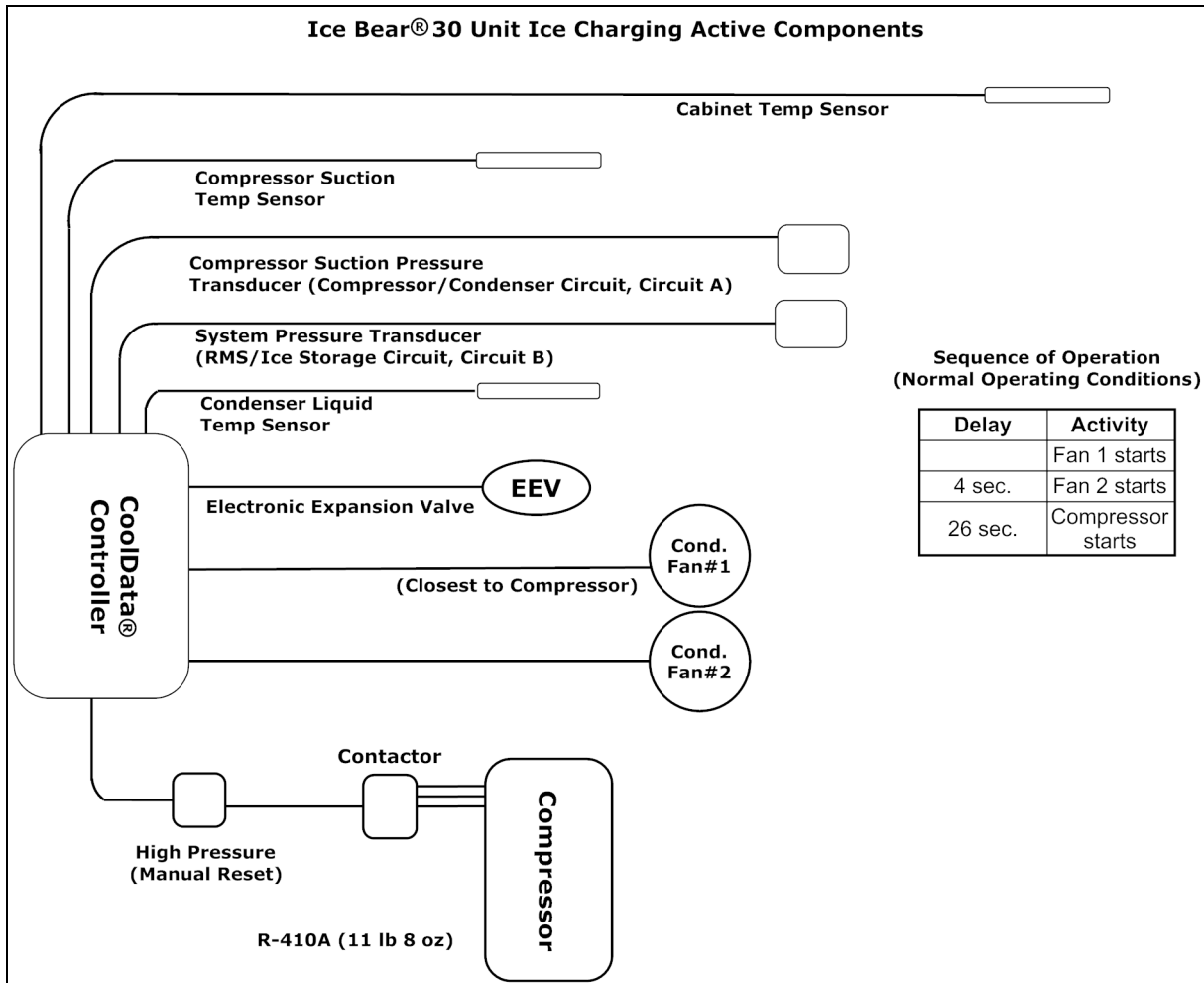

Figure 9 – Ice Charging Active Components & Operating Sequence

NOTE: The Ice Bear® 30 unit has a short cycle prevention delay of 5 minutes from the end of the previous charging cycle to the start of the next charging cycle.

NOTE: Refer to *Appendix A – Ice Bear® 30 Unit Detailed Sequence of Operation* for details, including low ambient startup conditions.

Cooling (Ice Melt)

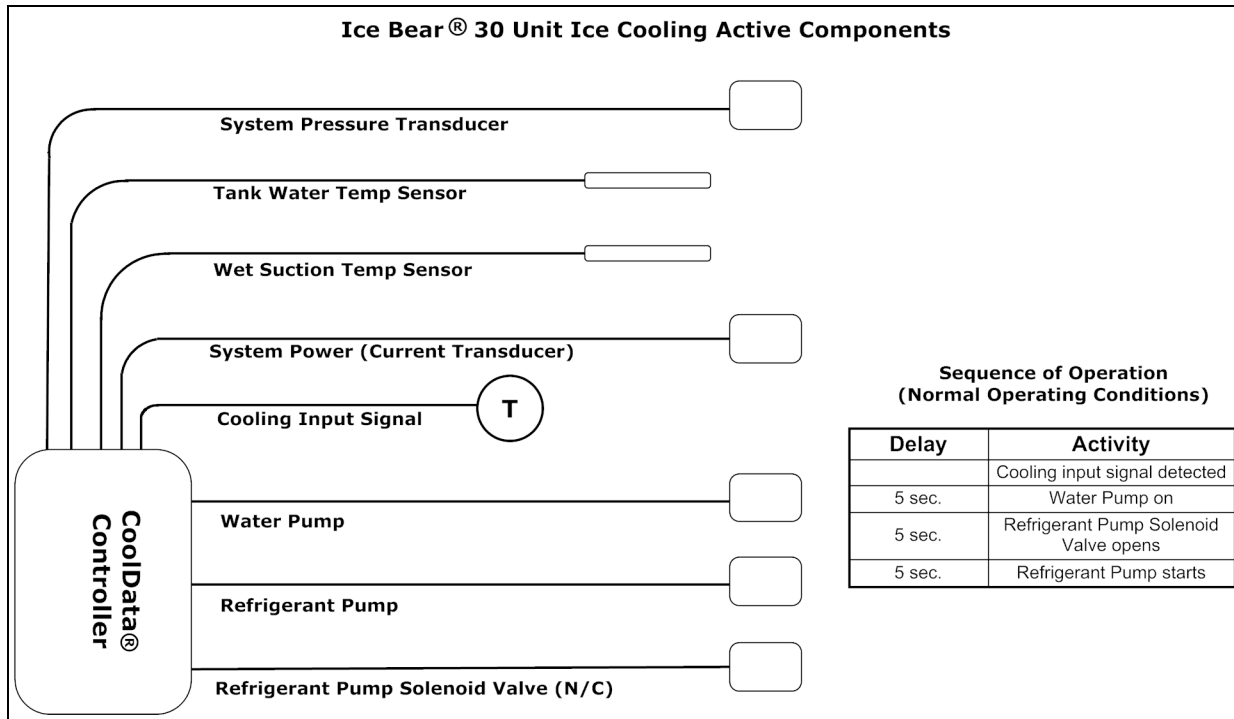

Figure 10 – Ice Cooling Active Components & Operating Sequence

NOTE: Refer to *Appendix A – Ice Bear® 30 Unit Detailed Sequence of Operation* for details.

CoolData® Controller

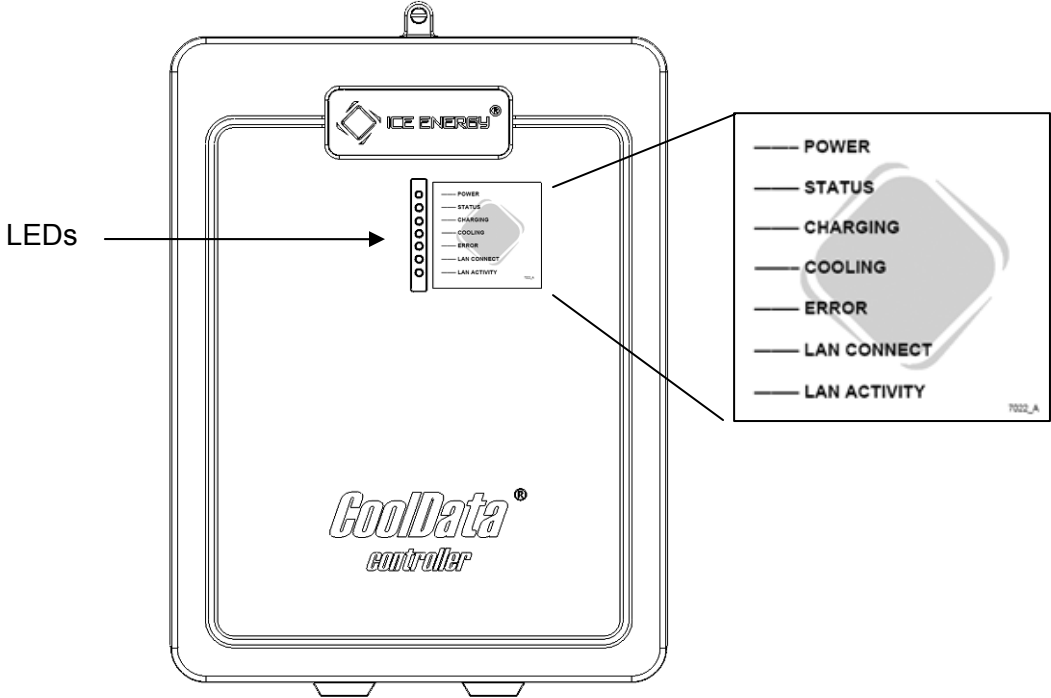

Figure 11 – CoolData® Controller LEDs Location

CoolData Controller LEDs

For reference, below are descriptions of the CoolData® Controller LEDs and their respective codes.

LED	Description
POWER	Lit when power is supplied to the COOLDATA CONTROLLER.
STATUS	Blinks when indicating the current system status. This LED will not indicate error status (see following section, <i>CoolData Controller LED Codes</i>).
CHARGING	Blinks if the system is in the process of making ice. This may include delays where no activity is apparent.
COOLING	Blinks if the system is in the process of providing cooling by melting ice. This may include delays where no activity is apparent..
ERROR	Blinks to indicate the current error code (see following section, <i>CoolData Controller LED Codes</i>).
LAN CONNECT	Lit if the ICE BEAR UNIT is connected to a Local Area Network (LAN).
LAN ACTIVITY	Blinks if network activity is present.

CoolData Controller LED Codes

LED	Activity	Description
STATUS	1 blink	Idle
	2 blinks	ICE BEAR UNIT active, backup system inactive (Ice Make / Ice Cooling state determined by other LEDs)
	3 blinks	ICE BEAR UNIT may be active, backup system is active (Ice Make / Ice Cooling state determined by other LEDs)
CHARGING (ICE MAKE)	Off	Idle
	1 blink	COMPRESSOR short cycle delay (5 min) or Charging delay (based on estimated charging time). Temperature is determined during final 30 seconds of delay.
	3 blinks	Startup control delay of 10 seconds
	On	Actively Charging
COOLING (ICE COOLING)	Off	Idle
	1 blink	SOLENOID VALVE open delay
	2 blinks	REFRIGERANT PUMP running at minimum output for 10 seconds
	On	Actively providing Ice Cooling. REFRIGERANT PUMP runs at configured output.
ERROR	1 blink	Ice Make not allowed
	2 blinks	Ice Cooling not allowed
	3 blinks	Ice Make and Ice Cooling not allowed
	4 blinks	Bypass active
	5 blinks	System disabled

Service Switch

The SERVICE SWITCH (see Figure 3 for location) allows a technician to switch modes for the purpose of servicing the unit. The SERVICE SWITCH (represented in Figure 12) provides three service modes:

- **BYPASS MODE** – allows the cooling signal to go directly to the existing/base equipment (thereby bypassing the ICE BEAR UNIT).
- **AUTO MODE** – allows the cooling signal to go directly to the ICE BEAR UNIT's CoolData[®] CONTROLLER. The CoolData CONTROLLER then decides the appropriate course of action (based on time, ice availability, and on-board programming). AUTO MODE is the normal operation mode for the system.
- **OFF** – **Warning: This mode does not disable line voltage.** This mode only disables cooling control signals going through the CoolData CONTROLLER. All other functions will continue to operate. Follow approved servicing & maintenance procedures for all equipment; i.e., lockout/tagout procedures.

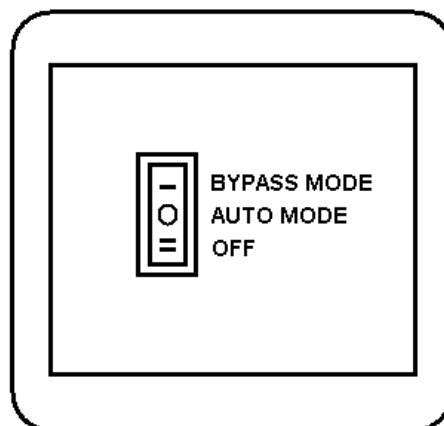

Figure 12 – Service Switch

NOTE: SERVICE SWITCH may differ in appearance from that shown in Figure 12.

Troubleshooting Procedures

This manual assumes that you have already performed basic HVAC troubleshooting procedures. For example, you should have already verified the following:

- Thermostat is operational.
- Air filters are clean.
- There are no frozen evaporator coils.
- System airflow is fully functional.
- Power is connected to all peripheral equipment.

No Apparent Power to System

Symptom	Probable Cause	Recommendation
COOLDATA display is blank; i.e., COOLDATA CONTROLLER red LED lights are not on, as observed through the LED DISPLAY WINDOW on the left SERVICE DOOR (facing the CONDENSER COIL). See Figure 11.	No power (Power LED is not lit.)	<ul style="list-style-type: none"> • Check ICE BEAR UNIT AC power source. • Check all power switches/plugs/breakers & wiring connections. • Check secondary FUSES located on the bottom of the CONTROL BOX located behind the right SERVICE DOOR (facing the CONDENSER COIL). • (460 volt units) Check primary & secondary FUSES located on the bottom of the CONTROL BOX located behind the right SERVICE DOOR (facing the CONDENSER COIL). • Check FUSE located in COOLDATA CONTROLLER BOX (see Figure 4).
	Faulty COOLDATA CONTROLLER	<ul style="list-style-type: none"> • Verify input voltage. • Replace COOLDATA CONTROLLER. See Figure 3.

Ice Charging Mode (typical nighttime/off-peak operation)

You may need to manually activate this mode for troubleshooting. Refer to *Service Switch* section.

Symptom	Probable Cause	Recommendation
No COMPRESSOR or CONDENSER FAN operation	System off on low suction pressure (off at 50 psi)	<ul style="list-style-type: none"> • Check refrigerant charge on COMPRESSOR / air CONDENSER side • Check EEV for proper operation.
	System off on low system pressure (off at 50 psi)	Check refrigerant charge on ICE STORAGE TANK side.
	CONDENSER liquid temperature SENSOR failure	<ul style="list-style-type: none"> • Verify functionality of the SENSOR; replace SENSOR as necessary. • Check manual reset high pressure cutoff switch.
CONDENSER FANS on but COMPRESSOR does not run	System off on manual reset high pressure cutoff SWITCH	<ul style="list-style-type: none"> • Check for intermittent CONDENSER FAN operation due to FAN MOTOR thermal overload. Reset high pressure SWITCH. • Check for dirty CONDENSER COIL or CONDENSER COIL blockage; clean and reset high pressure cutoff SWITCH.
	CABINET temperature SENSOR failure.	<ul style="list-style-type: none"> • Verify functionality of the SENSOR; replace SENSOR as necessary. • Check manual reset high pressure cutoff SWITCH.
CONDENSER FAN #1 on only / COMPRESSOR and CONDENSER FAN #2 does not run	Loss of 24 volts from control TRANSFORMER	Check 24 volt control wiring and reset 24 volt control TRANSFORMER FUSE.
	Defective 24 volt control TRANSFORMER.	Replace 24 volt control TRANSFORMER.
CONDENSER FANS #1 and #2 on / no COMPRESSOR (Verify that this is not during startup sequence.)	COMPRESSOR off on thermal overload	Check EEV control wiring, verify proper EEV operation. Allow COMPRESSOR to cool prior to restarting.
	Dirty or defective COMPRESSOR CONTACTOR	<ul style="list-style-type: none"> • Confirm 24 volt control signal to CONTACTOR COIL. • Clean CONTACTOR CONTACTS. • Replace COMPRESSOR CONTACTOR.

Ice Charging Mode (typical nighttime/off-peak operation) (cont.)

Symptom	Probable Cause	Recommendation
COMPRESSOR and only #1 CONDENSER FAN operating	CONDENSER liquid temperature below 40° F	Normal operation
	CONDENSER liquid temperature above 45° F	<ul style="list-style-type: none"> • Repair / replace cabinet TEMPERATURE SENSOR. • Repair / replace inoperative FAN RELAY. • Repair / replace inoperative CONDENSER FAN.
System did not make ice.	Charging COMPRESSOR failure	See <i>Appendix C – System Refrigerant Recovery, Evacuation & Charging Procedures</i> .
	Low refrigerant charge on charging COMPRESSOR circuit	Perform refrigerant leak search. Recover refrigerant charge, repair leak source per <i>Appendix C – System Refrigerant Recovery, Evacuation & Charging Procedures</i> . Refer to field nameplate for total system refrigerant charge.
	Low refrigerant charge on ice storage circuit	<ul style="list-style-type: none"> • Observe SIGHT GLASSES on refrigerant RECEIVER (see Figure 5). Upon initiation of Ice Charging cycle, lower SIGHT GLASS must be full and liquid level should just be visible at the bottom of the upper SIGHT GLASS. • Perform refrigerant leak search. Recover refrigerant charge, repair leak source per <i>Appendix C – System Refrigerant Recovery, Evacuation & Charging Procedures</i>. Refer to field nameplate for total system refrigerant charge.

Ice Charging Mode (typical nighttime/off-peak operation) (cont.)

Symptom	Probable Cause	Recommendation
Insufficient Ice Charging	Low refrigerant charge	<ul style="list-style-type: none"> Using the field SERVICE SWITCH, manually switch the ICE BEAR 30 UNIT into Bypass mode and verify operating pressures (to determine whether or not UNIT shuts off on low pressure). See <i>Service Switch</i> section. Observe SIGHT GLASSES on refrigerant RECEIVER (see Figure 5). Upon initiation of Ice Charging cycle, lower SIGHT GLASS must be full and liquid level should just be visible at the bottom of the upper SIGHT GLASS. Perform refrigerant leak search. Recover refrigerant charge, repair leak source per instructions in <i>Appendix C – System Refrigerant Recovery, Evacuation & Charging Procedures</i>. Refer to field nameplate for total system refrigerant charge.
	RMS/Ice Storage Circuit PRESSURE SENSOR failure	<ul style="list-style-type: none"> Check RMS/Ice Storage Circuit control PRESSURE SENSOR reading against gauge. Note that the PRESSURE SENSOR reading is in absolute pressure (psia). See <i>Table 5. Altitude vs. Atmospheric Pressure</i> for absolute pressure conversions. Ensure proper connection between wiring harness and PRESSURE SENSOR. Replace PRESSURE SENSOR if necessary.
	COMPRESSOR suction TEMPERATURE SENSOR failure	<ul style="list-style-type: none"> Check wiring of TEMPERATURE SENSOR and replace as necessary.
Upon full discharge, a significant amount of ice remains in the STORAGE TANK.	WATER PUMP is not functioning properly.	<ul style="list-style-type: none"> Verify that the WATER PUMP runs. Verify water distribution circuit has flow. Replace the WATER PUMP, if necessary.
	Fouled water side HEAT EXCHANGER	Back flush water side HEAT EXCHANGER. Contact Ice Energy Product Services for more information.

Ice Charging Mode (typical nighttime/off-peak operation) (cont.)

Symptom	Probable Cause	Recommendation
Dead COILS (less than three dead COILS on any given Ice Charge is acceptable). No ice on COLLECTION HEADERS.	Noncondensibles in refrigerant	Reclaim refrigerant charge and follow recommendations in <i>Appendix C – System Refrigerant Recovery, Evacuation & Charging Procedures</i> . Refer to field nameplate for total system refrigerant charge.
Ice Charging won't stop.	SYSTEM PRESSURE SENSOR failure	<ul style="list-style-type: none"> • Check for damaged wiring. Replace PRESSURE SENSOR, as necessary. • Verify pressure with a calibrated gauge.
	COMPRESSOR CONTACTOR shorted closed	Check for damaged COMPRESSOR CONTACTOR and replace as necessary.
	Corrupt control program	Verify program parameters.
	COOLDATA CONTROLLER failure (control CONTACTS shorted closed)	Replace COOLDATA CONTROLLER, as necessary.
Unit shuts off due to low charging COMPRESSOR suction pressure condition.	Low refrigerant charge.	Perform refrigerant leak search. Recover refrigerant charge, repair leak source, follow instructions in <i>Appendix C – System Refrigerant Recovery, Evacuation & Charging Procedures</i> . Refer to field nameplate for total system refrigerant charge.
	Loss of COMPRESSOR suction PRESSURE SENSOR signal	<ul style="list-style-type: none"> • Check wiring from PRESSURE SENSOR to CONTROL BOX. Repair as necessary. • Replace PRESSURE SENSOR. • Verify pressure with a calibrated gauge.

Ice Cooling (Ice Bear unit / Ice Bear unit and DX)

You may need to force UNIT into manual Ice Cooling mode. Refer to parameters in *Sequence of Operation* section.

Symptom	Probable Cause	Recommendation
ICE BEAR UNIT won't go into Ice Cooling mode	Time set incorrectly or is outside the programmed Ice Cooling period.	Check the program and time setting.
	No cooling signal input received at the ICE BEAR UNIT.	<ul style="list-style-type: none"> • Verify call for cooling from space thermostat. • Verify call for cooling at COOLDATA BOARD. Terminal I1: check for 24VAC
	ICE BEAR UNIT SERVICE SWITCH in off position	Set SERVICE SWITCH to Auto mode. See <i>Service Switch</i> section.
	ICE BEAR 30 UNIT SERVICE SWITCH in Bypass position	Set SERVICE SWITCH to Auto Mode. See <i>Service Switch</i> section.
	Ice is completely exhausted.	<ul style="list-style-type: none"> • Verify Power sources. • Verify Ice Charging function, (e.g., check pressures, check for refrigerant leaks). • Verify cooling signal.
In Ice Cooling mode, but REFRIGERANT PUMP is not running.	No 208/230 VAC power to INVERTER	<ul style="list-style-type: none"> • Verify all wiring connections. • Check REFRIGERANT PUMP 208/230VAC 1P load power at COOLDATA electrical TERMINALS S3 and S4 to INVERTER. • Check REFRIGERANT PUMP 208/230VAC 1P load power at INVERTER TERMINAL connection block.
	No 5 VDC control power to INVERTER	<ul style="list-style-type: none"> • Verify wiring connections from COOLDATA to INVERTER • Verify 5 VDC signal at INVERTER connector PINS • Verify analog control signal at INVERTER connector PINS • Replace INVERTER.
	REFRIGERANT PUMP MOTOR is off due to INVERTER over current protection. (NOTE: PUMP turns on and then off upon startup.)	<ul style="list-style-type: none"> • Verify that REFRIGERANT PUMP ISOLATION VALVES are open and SOLENOID VALVE is functional. • Replace REFRIGERANT PUMP.

Ice Cooling (Ice Bear unit / Ice Bear unit and DX) (cont.)

Symptom	Probable Cause	Recommendation
Replacement INVERTER malfunction (all COOLDATA LEDs except LAN Activity LED are on)	INVERTER 5 VDC control wiring is reversed.	Reverse wiring connections.
Replacement REFRIGERANT PUMP malfunction	No refrigerant delivery to ICE- COIL	Verify INVERTER to REFRIGERANT PUMP wiring connection.

Ice Cooling (cooling the conditioned space)

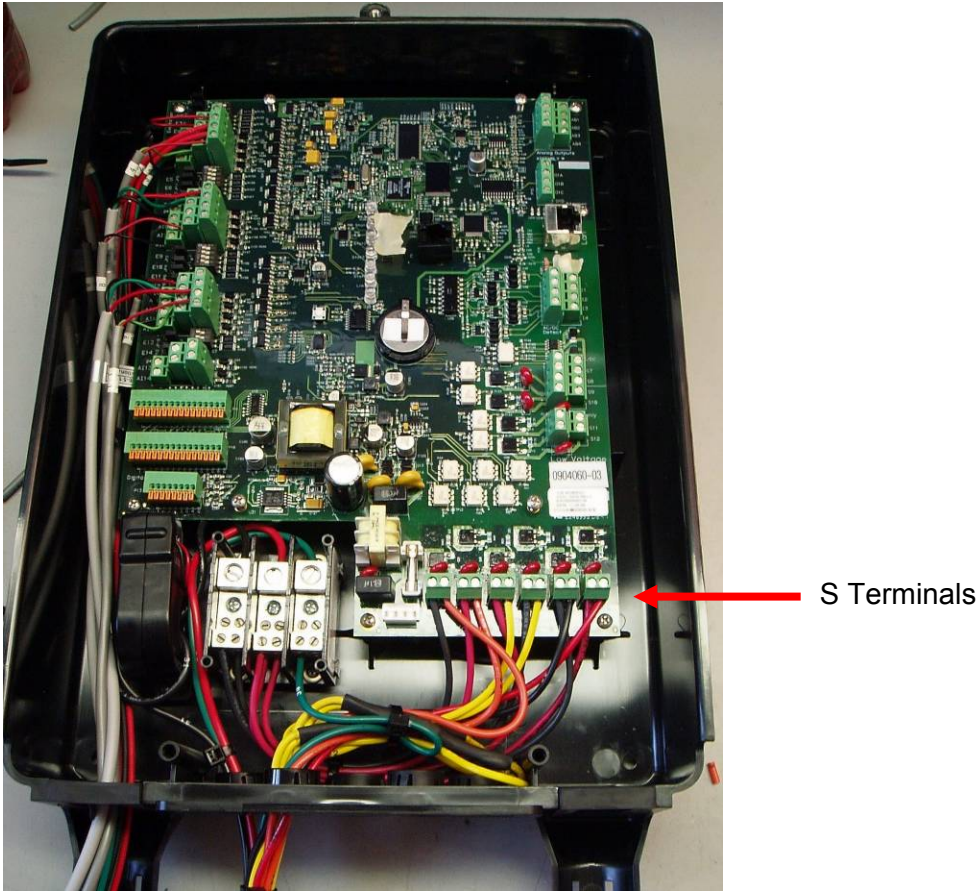

Figure 13 – CoolData® Terminals

Symptom	Probable Cause	Recommendation
In Ice Cooling mode, but WATER PUMP is not running.	Faulty WATER PUMP	<ul style="list-style-type: none">• Check WATER PUMP wiring.• Check S terminals (See Figure 13.)<ul style="list-style-type: none">• left = Line; right = Load• Right terminal of each pair should have > 200VAC.• Test and repair or replace, as necessary.
In Ice Cooling mode, WATER PUMP is running but no flow.	Damaged IMPELLER; plugged TANK, PUMP intake, or PLATE HEAT EXCHANGER	<ul style="list-style-type: none">• Check water level.• Check to ensure that lines are free of blockage.• Ensure all VALVES are open.• Replace WATER PUMP.• Back flush water side HEAT EXCHANGER. Contact Product Services for more information.

Ice Cooling (cooling the conditioned space) (cont.)

Symptom	Probable Cause	Recommendation
WATER PUMP runs continuously or intermittently without a call for cooling.	WATER PUMP is in normal low ambient protection operation.	Refer to <i>Low Ambient Conditions</i> section to verify that WATER PUMP is in low ambient protection operation.
	Ambient TEMPERATURE SENSOR failure	<ul style="list-style-type: none"> Verify that ambient temperature is above 40 °F. Replace TEMPERATURE SENSOR, if necessary.
In Ice Cooling mode, but neither REFRIGER-ANT PUMP or WATER PUMP is running.	Faulty COOLDATA CONTROLLER	<ul style="list-style-type: none"> Replace COOLDATA CONTROLLER.
Partial discharge (ice remaining in ICE STORAGE TANK)	Premature high pressure cutoff due to damaged WATER PUMP IMPELLER or plugged TANK or WATER PUMP intake	<ul style="list-style-type: none"> Check to ensure that lines are free of blockage. Ensure all VALVES are open.
	Premature high pressure cutoff due to faulty WATER PUMP.	Replace WATER PUMP.
	Premature high pressure cutoff due to failed PRESSURE SENSOR	Check control PRESSURE SENSOR reading against actual system gauge pressure. Note that the PRESSURE SENSOR reading is in absolute pressure (psia). See <i>Table 5. Altitude vs. Atmospheric Pressure</i> for absolute pressure conversions. Replace PRESSURE SENSOR if necessary.
	Low load condition (THERMOSTAT is at set point).	No action required.
	Program shut off early.	Check COOLDATA CONTROLLER program.
	Incorrect program	Refer to ICE BEAR 30 UNIT configuration number for proper program.

Ice Cooling (cooling the conditioned space) (cont.)

Symptom	Probable Cause	Recommendation
Ice Cooling mode won't stop.	PRESSURE SENSOR failure	Check control PRESSURE SENSOR reading against actual system gauge pressure. Note that the PRESSURE SENSOR reading is in absolute pressure (psia). See <i>Table 5. Altitude vs. Atmospheric Pressure</i> for absolute pressure conversions. Replace PRESSURE SENSOR, if necessary.
	Damaged or incorrect control wiring.	Test and repair or replace control wiring, as necessary. Refer to the ICE BEAR UNIT installation instructions.
PUMPS are running but no cooling.	Non-Ice Energy equipment failure.	Perform basic HVAC troubleshooting on the non-Ice Energy components.
	Blocked or limited refrigerant flow to ICE-COIL	Verify refrigerant flow.
	PRESSURE SENSOR has failed "low" (i.e., pressure reading in COOLDATA is falsely low, as verified by a calibrated gauge).	Check control PRESSURE SENSOR reading against actual system gauge pressure. Note that the PRESSURE SENSOR reading is in absolute pressure (psia). See <i>Table 5. Altitude vs. Atmospheric Pressure</i> for absolute pressure conversions. Replace PRESSURE SENSOR, if necessary.

Other Components

Symptom	Probable Cause	Recommendation
External water leak	Loose LINK-SEALS	Verify torque. Refer to <i>Appendix D – Service & Maintenance Procedures</i> for more information.
	WATER PUMP VALVE flanges not tight	Verify torque.
	WATER PUMP SEAL damaged	<ul style="list-style-type: none"> • Replace WATER PUMP SEAL. • Replace WATER PUMP.

Ice-Coil Diagnostics

Symptom	Probable Cause	Recommendation
High ΔT at EVAPORATOR (greater than 25 °F)	High load condition	Allow system to stabilize.
	Excessive fresh air intake (dry climate)	Adjust intake, as necessary.
Abnormally low ΔP at REFRIGERANT PUMP (less than 5 psid)	Reduced refrigerant flow resulting from loss of charge	Perform refrigerant leak search. Recover refrigerant charge, repair leak source, following instructions in <i>Appendix C – System Refrigerant Recovery, Evacuation & Charging Procedures</i> . Refer to field nameplate for total system refrigerant charge.
High ΔP at REFRIGERANT PUMP (in excess of 45 psi)	Restriction/blockage of refrigerant lines or EVAPORATOR COIL	Isolate loop from system and perform pressure test on refrigerant lines and/or EVAPORATOR COIL.
	Closed REFRIGERANT PUMP SOLENOID VALVE or REFRIGERANT PUMP service BALL VALVE(S)	Check REFRIGERANT PUMP SOLENOID VALVE and service BALL VALVES are open.
Low ΔT (less than 15° F) at EVAPORATOR	Low refrigerant charge	Perform refrigerant leak search. Recover refrigerant charge, repair leak source, following instructions in <i>Appendix C – System Refrigerant Recovery, Evacuation & Charging Procedures</i> . Refer to field nameplate for total system refrigerant charge.
	Non-Ice Energy EVAPORATOR COIL is frozen.	Perform basic HVAC troubleshooting on the non-Ice Energy components.
	Low flow on REFRIGERANT PUMP	Verify COOLDATA program parameters.
	Excessive fresh air intake (humid climate)	Adjust intake, as necessary.

CoolData Programming

Symptom	Probable Cause	Recommendation
Indicated power measurement is incorrect or doesn't match measured.	<ul style="list-style-type: none">• Incorrect voltage configured• Damaged CURRENT TRANSDUCER• Incorrect number of wire wraps on CURRENT TRANSDUCER• Voltage/current selector switch in incorrect position.• CURRENT TRANSDUCER switch may be in wrong position.	Test and repair or replace, as necessary.
No cooling provided when call for cooling is initiated	Program Failure	Contact Ice Energy.

Appendix A – Ice Bear® 30 Unit Detailed Sequence of Operation

Ice Charging

NOTE: Upon a call for COMPRESSOR operation, there is a minimum of a 30 second startup delay.

Seq.	Status	Charging LED	Delay	Activity
1	idle	off (idle)		CONDENSER FANS and COMPRESSOR not running
2	startup delays	flashes 1x	30 sec. before COMPRESSOR starts	<ul style="list-style-type: none"> • EEV resets • if cabinet temp ≥ 40 °F, FAN 2 starts • if cabinet temp < 40 °F, FAN 2 start is delayed 3 min.
			26 sec. before COMPRESSOR starts	<ul style="list-style-type: none"> • if cabinet temp ≥ 20 °F, FAN 1 starts • if cabinet temp < 20 °F, FAN 1 start is delayed 3 min.
			3 sec. before COMPRESSOR starts	initial EEV position is set and EEV opens to set position
3	COMPRESSOR startup	flashes 2x		<ul style="list-style-type: none"> • EEV position verified • COMPRESSOR starts
4	settling delay charging	flashes 3x solid	10 sec.	settling delay
5				<ul style="list-style-type: none"> • superheat set point computed • target EEV position computed based on superheat set point • EEV position is adjusted • if CONDENSER liquid temp is 45 °F – 67 °F, FAN 2 cycles • if CONDENSER liquid temp is 45 °F – 63 °F, FAN 1 cycles • if charge complete conditions are met (system pressure of 98.5 psia) or charging no longer allowed (e.g., outside charging time window): <ul style="list-style-type: none"> ○ FAN 1, FAN 2, and COMPRESSOR shut down ○ EEV closes ○ Charging mode goes to idle

NOTE: The Ice Bear® 30 unit has a short cycle prevention delay of 5 minutes from the end of the previous charging cycle to the start of the next charging cycle.

Ice Cooling

Seq.	Status	Cooling LED	Delay	Activity
1				Cooling input signal detected
2	WATER PUMP startup	flashes 1x	5 sec.	WATER PUMP turns on
3	REFRIGERANT PUMP SOLENOID VALVE open	flashes 2x	5 sec.	main SOLENOID VALVE is opened
4	REFRIGERANT PUMP startup		5 sec.	REFRIGERANT PUMP is powered (at minimum output)
5	cooling	solid	10 sec.	<ul style="list-style-type: none"> • REFRIGERANT PUMP output is adjusted to meet configured and requested load • if ice is exhausted (typical system pressure of 165 psia, or water temp of 48 °F), call for cooling has been removed, or Ice Cooling is no longer allowed: <ul style="list-style-type: none"> ○ WATER PUMP shuts down ○ REFRIGERANT PUMP shuts down ○ main SOLENOID VALVE closes ○ Ice Cooling mode goes to idle

Low Ambient Conditions

The ICE BEAR UNIT's ICE STORAGE TANK is insulated to prevent excessive system freezing. The ICE BEAR UNIT also includes an automatic control feature that periodically circulates water to help prevent freezing in water distribution components.

Fan Cycling (CABINET temperature less than 40 °F)

During low ambient temperatures, the ICE BEAR UNIT's two FANS will cycle as follows based on CONDENSER liquid temperature (CLt):

- FAN #2 (on left when facing CONDENSER)
 - Off if CLt < 45 °F
 - On if CLt > 67 °F and FAN1 has been on for 3 min
- FAN #1 (on right when facing CONDENSER)
 - Off if CLt < 45 °F and FAN2 has been off for 5 min
 - On if CLt > 63 °F

Water Pump Cycling

Based on CABINET temperature (CBt), the ICE BEAR UNIT's WATER PUMP will cycle (for a 20 minute period) for freeze protection as follows:

- 1) Runs 5% duty cycle at 33/35 °F ambient
- 2) Runs 20% duty cycle at 30/33 °F ambient
- 3) Runs 50% duty cycle at 27/30 °F ambient
- 4) Runs 75% duty cycle at 24/27 °F ambient
- 5) Runs 100% duty cycle at 21/24 °F ambient

The cycle will repeat, as necessary, based on measured CABINET temperature.

The five program levels, or thresholds, are illustrated below:

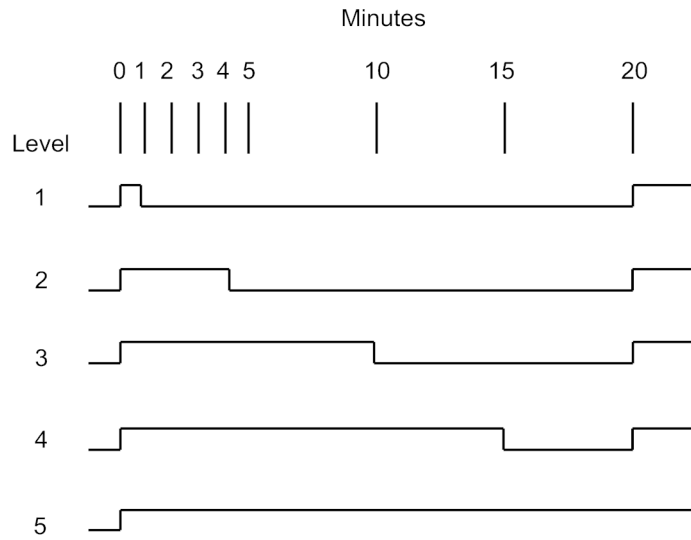

If the above parameters are incompatible with your region, or your unit requires an extended shutdown period, contact productservices@ice-energy.com.

Appendix B – System Pressure & Temperature Thresholds

The following thresholds are defined within the CoolData[®] controller program:

Table 4. Pressure & Temperature Thresholds and Effects

Threshold	Description
End of Ice Charging	Typically, end of Ice Charging pressure cutoff is 98.5 psia. Ice Charging will end 5 minutes after system pressure drops and remains below this threshold.
End of Ice Cooling condition 1 (either condition 1 or 2 can end Ice Cooling)	Pressure reading needs to go above 165 psia for 5 minutes for ice exhausted state to be recognized.
End of Ice Cooling condition 2 (either condition 1 or 2 can end Ice Cooling)	Water temperature needs to go above 48 °F for 5 minutes for ice exhausted state to be recognized.
Low Pressure System disable	If the suction pressure or system pressure reading drops below 50 psia for 25 seconds, the system will enter a “Low pressure Call for Service” state and will not operate. This state will recover if the pressure goes above 50 psia for 24 hours.

NOTE: CoolData values are expressed in absolute pressure (psia).

Use the table below to determine standard atmospheric pressure at your elevation, and then add it to your gauge pressure readings to determine absolute pressure.

Table 5. Altitude vs. Atmospheric Pressure

Altitude, ft	Pressure, psia
0	14.696
1,000	14.175
2,000	13.664
3,000	13.173
4,000	12.682
5,000	12.230
6,000	11.778
7,000	11.341
8,000	10.914

Appendix C – System Refrigerant Recovery, Evacuation & Charging Procedures

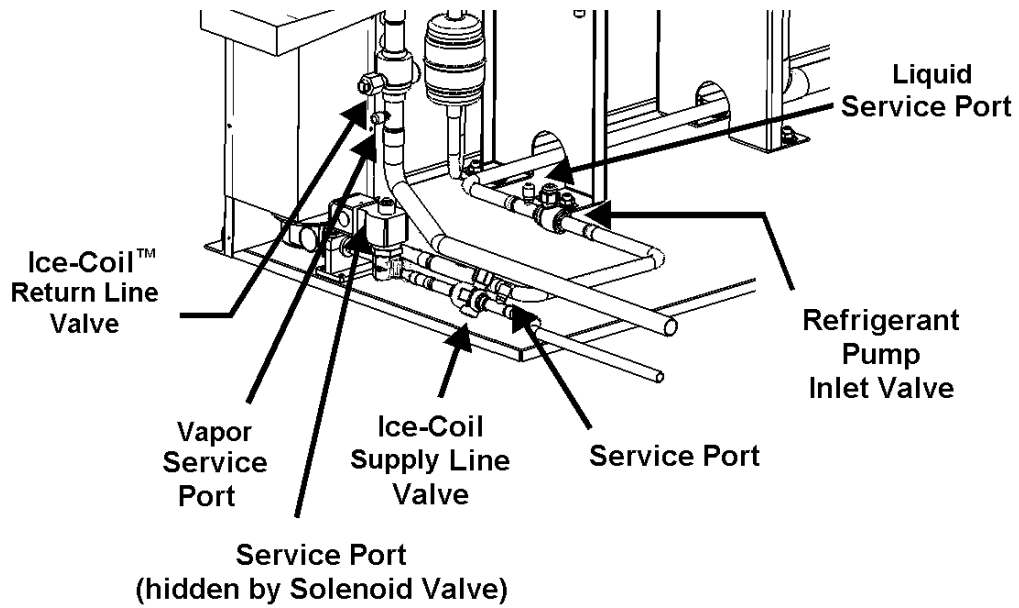

Figure 14 – Valve & Port Locations – Left Side

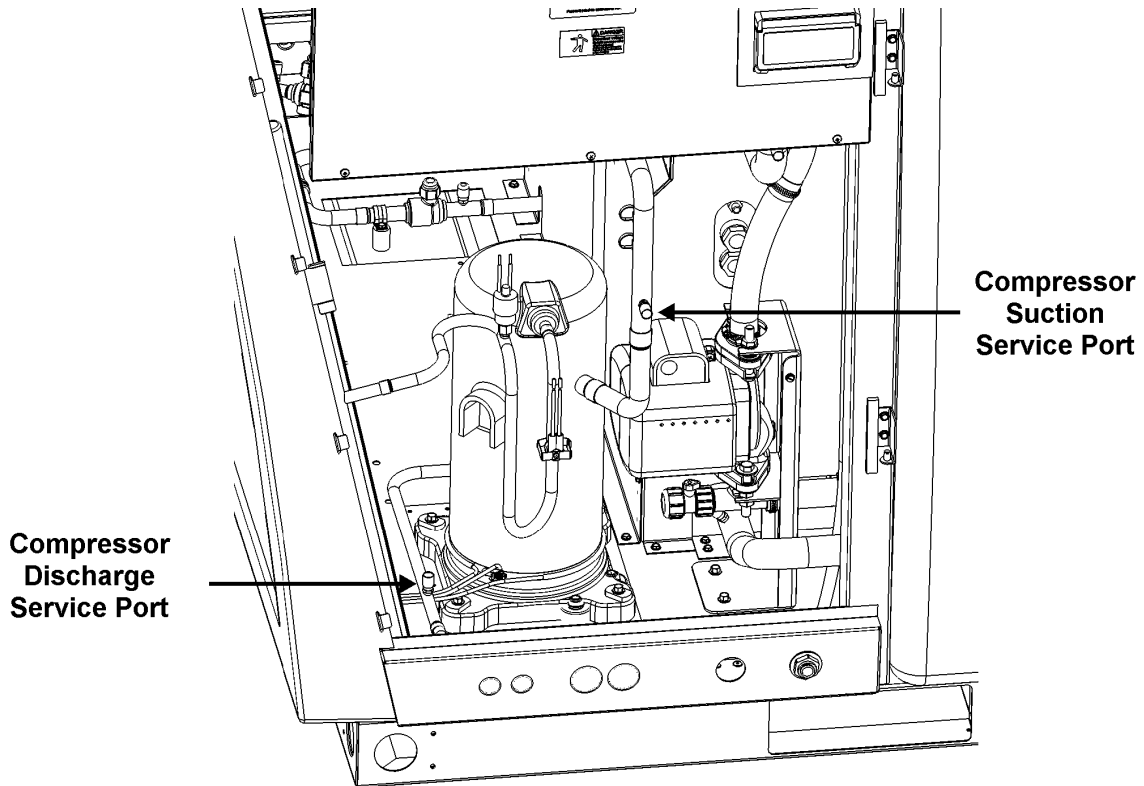

Figure 15 – Port Locations – Right Side

System Refrigerant Recovery

Equipment Required

- Approved refrigerant recovery cylinders rated for R-410A refrigerant
- Approved refrigerant recovery machine rated for R-410A refrigerant
- Accurate digital refrigerant scale
- Refrigerant manifold and hose set rated for R-410A refrigerant
- Two (2) Schrader core removal tools

General Notes

- Read, understand, and follow refrigerant recovery machine manufacturer's operating, servicing and safety instructions.
- To speed up the refrigerant recovery process, it is recommended that the ICE STORAGE TANK be free of ice prior to removal of refrigerant from the RMS/Ice Storage Circuit.

RMS/Ice Storage Circuit

- Push/Pull liquid refrigerant recovery method followed up by Liquid/Vapor recovery is recommended on this circuit.
- Recommended refrigerant recovery points: liquid & vapor SERVICE PORTS (refer to Figure 14).
- Removal of Schrader cores is recommended to shorten refrigerant recovery time.

Compressor/Condenser Circuit

- Liquid/Vapor recovery method is recommended.
- Recommended refrigerant recovery points: COMPRESSOR suction & CONDENSER liquid SERVICE PORTS (refer to Figure 5).
- Removal of Schrader cores is recommended to shorten refrigerant recovery time.

NOTE: Do not mix refrigerant of the two circuits during the recovery process. RMS/Ice Storage Circuit must be free of polyolester (POE) oil when recycling refrigerants during a system repair.

RMS/Ice Storage Circuit Evacuation

Materials Required

- Evacuation pump (10CFM recommended)
- Two (2) 3/8" (minimum) evacuation hoses with 1/4" hose adaptors
- Electronic vacuum gauge (manifold gauge not recommended)
- Vacuum tree
- Two (2) Schrader core remover tools

General Notes

- To speed up the evacuation process, it is recommended that the ICE STORAGE TANK be free of ice prior to evacuation of the RMS/Ice Storage Circuit.
- Ensure that all repairs have been completed and that you have a leak-free system before adding water to the ICE STORAGE TANK (so as not to introduce water into the refrigerant circuit).

- Read, understand, and follow the evacuation pump manufacturer’s operating, servicing, and safety instructions.
- Evacuate Ice Cooling (ICE-COIL) and RMS/Ice Storage Circuit side of system to 500 microns or less. Measure with an electronic vacuum gauge at a point farthest from the vacuum connections to get a “true” reading.
- Use approved 3/8” evacuation hoses, hose adaptors, evacuation tree, 7.5 to 10 CFM evacuation pump, and Schrader core removers to facilitate a timely and efficient system evacuation. Manifold gauges are not recommended for evacuating.
- Use the following recommended hose connection points (to ensure complete nitrogen and contaminant removal, always evacuate from the highest connection point in the system):
 - access port on inlet to REFRIGERANT PUMP inside the ICE BEAR UNIT RMS area (see Figure 14)
 - access port on ICE-COIL return line inside the ICE BEAR UNIT RMS area (see Figure 14)
 - access port(s) at the ICE-COIL (reference ICE-COIL installation instructions)
- Use two (2) Schrader core remover tools to remove VALVE cores prior to attaching two (2) 3/8” (minimum), 36” length (maximum) evacuation hoses.
- Ensure that all isolation VALVES are open.

NOTE: A 3/8” to 1/4” hose to Schrader adaptor will be required for each connection point to the Schrader VALVE. Connect hoses to the vacuum tree on the vacuum pump, verifying tightness of connections at all points prior to starting evacuation.

Evacuation Procedure

After connecting hoses, start vacuum pump with vacuum pump ballast open. After pump quiets down from initial volume of air, close ballast VALVE and continue evacuating.

NOTE: Failure to close ballast VALVE will result in poor pump performance.

1. Evacuate system to 1500 microns, break vacuum with nitrogen to 0 psig. Let system set for a minimum of 15 minutes before proceeding to Step 2.

NOTE: A new system should reach this point within ½ hour. If a new system does not reach target level, terminate evacuation procedure and begin leak detection.

2. Evacuate system to 1000 microns, break vacuum with nitrogen to 0 psig. Let system set for a minimum of 15 minutes before proceeding to Step 3.
3. Evacuate system to 500 microns, valve off vacuum pump and observe vacuum gauge. System should hold steady at 500 microns for 15 minutes. An allowable rise to 750 microns before stabilizing is acceptable. The evacuation process should take no longer than 3 to 4 hours as determined by the ambient temperature of the coldest part of the system (3 to 4 hours is based on 70-75° F).

The length of time required to remove moisture from the system depends on the condition of the vacuum pump, vacuum pump oil, hoses, connection points, and the temperature of the system. The table below represents the temperature of the “coldest part” of the system.

<u>Temperature</u>	<u>Minimum Time</u>
90°F / 32°C	1 Hour +/-
80°F / 27°C	2 Hours +/-
70°F / 21°C	4 Hours +/-
60°F / 16°C	6 Hours +/-
50°F / 10°C	8 Hours +/-

Compressor/Condenser Circuit Evacuation

Equipment Required

- Evacuation pump (5 CFM recommended)
- (2) 3/8" (minimum) evacuation hoses with 1/4" hose adaptors
- Electronic vacuum gauge (manifold gauge not recommended)
- Vacuum tree
- Two (2) Schrader core remover tools

General Notes

- Read, understand, and follow the evacuation pump manufacturer's operating, servicing and safety instructions.
- Ensure that all repairs have been completed, refrigerant DRIER has been replaced and that you have a leak-free system prior to evacuation.
- Evacuate COMPRESSOR/CONDENSER Circuit side of system to 500 microns or less. Measure with an electronic vacuum gauge at a point farthest from the vacuum connections to get a "true" reading.
- Approved 3/8" evacuation hoses, hose adaptors, evacuation tree, 5 CFM evacuation pump, and Schrader core removers must be used to facilitate a timely and efficient system evacuation. Manifold gauges are not recommended for evacuating.
- Use the following recommended hose connection points (to ensure complete nitrogen and contaminant removal, always evacuate from the highest connection point in the system):
 - access port on CONDENSER liquid service port (see Figure 15)
 - access port on COMPRESSOR suction service port (see Figure 15)
- Use two (2) Schrader core remover tools to remove VALVE cores prior to attaching two (2) 3/8" (minimum), 36" length (maximum) evacuation hoses.
- Ensure that all isolation VALVES are open.

NOTE: A 3/8" to 1/4" hose to Schrader adaptor will be required for each connection point to the Schrader VALVE. Connect hoses to the vacuum tree on the vacuum pump, verifying tightness of connections at all points prior to starting evacuation.

Evacuation Procedure

After connecting hoses, start vacuum pump with vacuum pump ballast open. After pump quiets down from initial volume of air, close ballast VALVE and continue evacuating.

NOTE: Failure to close ballast VALVE will result in poor pump performance.

1. Evacuate system to 1500 microns, break vacuum with nitrogen to 0 psig. Let system set for a minimum of 15 minutes before proceeding to Step 2.

NOTE: A new system should reach this point within ½ hour. If a new system does not reach target level, terminate evacuation procedure and begin leak detection.

2. Evacuate system to 1000 microns, break vacuum with nitrogen to 0 psig. Let system set for a minimum of 15 minutes before proceeding to Step 3.
3. Evacuate system to 500 microns, valve off vacuum pump and observe vacuum gauge. System should hold steady at 500 microns for 15 minutes. An allowable rise to 750 microns before stabilizing is acceptable.

System Charging Procedures

Compressor/Condenser Circuit Charging

Refrigerant and charge amount: See unit nameplate.

Equipment/Materials Required

- Safety glasses and hand protection
- Accurate digital refrigerant scale
- Refrigerant manifold and hose set rated for refrigerant R-410A
- Two (2) Schrader core removal tools
- Virgin R-410A refrigerant recommended, system recycled refrigerant acceptable

General Notes

- Follow safety procedures with appropriate personal protective equipment.
- Read, understand, and follow refrigerant manifold set manufacturer's operating, servicing and safety instructions.
- Ensure that all repairs have been completed, refrigerant DRIER has been replaced and that you have a leak-free, evacuated system prior to charging.

Charging Procedure

Method of refrigerant charging: Weigh in as per unit nameplate.

Recommended refrigerant charging locations: COMPRESSOR suction & COMPRESSOR discharge SERVICE PORTS (refer to Figure 15)

1. Use two (2) Schrader core remover tools to remove VALVE cores prior to attaching manifold charging hoses.
2. Weigh liquid charge in through COMPRESSOR discharge SERVICE PORT. If unable to weigh entire charge into system using this method, COMPRESSOR may be started and charge may be finished by vapor charging through COMPRESSOR suction SERVICE PORT.

NOTES:

- Utilize unit refrigerant service hose entrances (see Figure 3) for manifold hoses if COMPRESSOR is to be run for finishing vapor charging.
 - Liquid SIGHT GLASS upstream of TXV is for reference and moisture indication only and is not to be used as a method of charging.
3. Reinstall two (2) Schrader VALVE cores prior to removal of charging hoses.

RMS/Ice Storage Circuit Charging

Equipment / Materials Required

- Safety glasses and hand protection
- Accurate digital refrigerant scale
- Refrigerant manifold and hose set rated for R-410A refrigerant
- Two (2) Schrader core removal tools
- Refrigerant tank heat blanket
- Virgin R-410A refrigerant recommended, system recycled refrigerant acceptable
- **NOTE:** No POE oil is permissible on this circuit.

General Notes

- Follow safety procedures with appropriate personal protective equipment.
- Read, understand, and follow refrigerant manifold set manufacturer's operating, servicing and safety instructions.
- Ensure that all repairs have been completed, refrigerant DRIER has been replaced and that you have a leak-free, evacuated system prior to charging
- Use one (1) Schrader core remover tool to remove VALVE core prior to attaching manifold charging hose.

Charging Procedure

Method of refrigerant charging: Weigh in as per unit nameplate (liquid only)

Recommended refrigerant charging location: liquid SERVICE PORT (refer to Figure 14)

1. Liquid charge only through RMS Schrader SERVICE PORT as designated above.
2. If unable to weigh entire charge into system using this method, COMPRESSOR may be started and charging finished by continuing to liquid charge through same PORT.
3. Alternate method is to utilize tank heater blanket to raise charging cylinder pressure.
4. Reinstall one (1) Schrader VALVE core prior to removal of charging hose.

Appendix D – Service & Maintenance Procedures

Link-Seal[®] Adjustments

During transit of the ICE BEAR UNIT, it is possible for LINK-SEALS surrounding the upper and lower COLLECTION HEADERS to loosen, causing leakage. If you notice any water leaking from the LINK-SEALS, follow the procedure below to ensure proper sealing.

1. Within the Refrigeration Management System (RMS) area, compress (or remove, if necessary) INSULATION blocking access to upper and lower COLLECTION HEADERS (see Figure 16 for an illustration of the LINK-SEAL surrounding the upper COLLECTION HEADER).

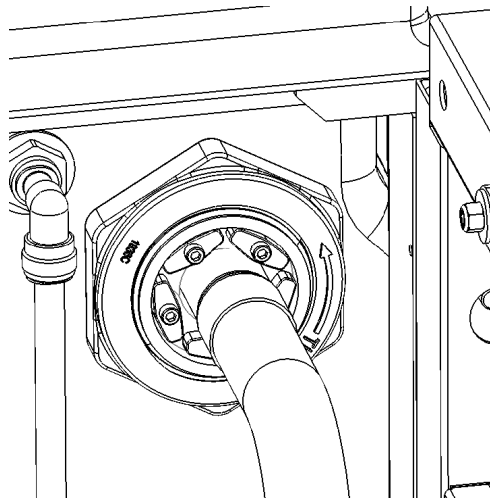

Figure 16 – Upper Link-Seal

2. Use a 3/8” drive inch-pound torque wrench (with a 6” long 5/32” ball-point hex-bit socket) to tighten in even increments all LINK-SEAL SCREWS in the sequence shown in Figure 17. Starting point is not critical. Final torque should be 20 in-lb. DO NOT tighten more than four turns at a time.

NOTE: Be careful not to over torque the LINK-SEAL SCREWS.

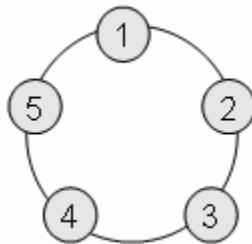

Figure 17 – Link-Seal Tightening Sequence

3. Reinstall INSULATION when done.

Water Pump Service & Maintenance

Preventive Maintenance: Inspection

Although the WATER PUMP is designed to provide years of worry-free service, it is a good maintenance practice to inspect the WATER PUMP for potential problems. If there is any evidence of leakage or damage, then repair or replace the PUMP.

The ICE BEAR UNIT's WATER PUMP is fitted with permanently lubricated BALL BEARINGS, which DO NOT require lubrication.

Replacing the Water Pump's Mechanical Seal

1. Ensure that the ICE BEAR UNIT's electrical power is disconnected and locked out.
2. Disconnect the 1" water HOSE inside the TANK to prevent siphoning (disconnect using either HOSE CLAMP). See Figure 18.

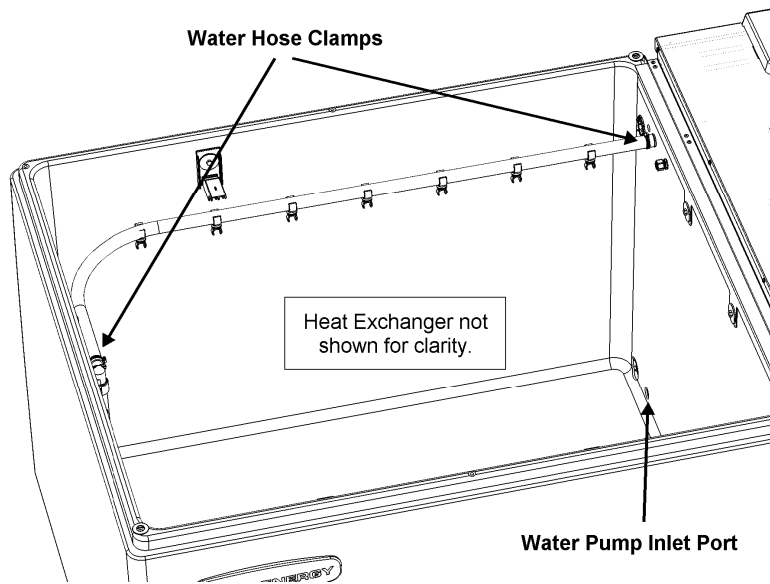

Figure 18 – Water Hose Clamps & Pump Inlet Port

3. In certain locations, draining of the ICE STORAGE TANK may not be feasible; therefore, simply blocking the PUMP INLET PORT inside the TANK will prevent water from draining while servicing. See Figure 18 for location of PUMP INLET PORT.
4. While holding the MOTOR BODY, unfasten the (4) BOLTS that attach the MOTOR to the PUMP CASING. Start by removing the (2) bottom BOLTS first, then slowly loosen the top (2) BOLTS. Allow the water to drain from the bottom of the PUMP. When the water has finished draining, remove the (2) top BOLTS. Remove the MOTOR straight out from the PUMP CASING, being careful of its attached IMPELLER. The MOTOR is heavy; do not drop it!
5. Locate the SNAP BUSHING in the center of the back of the MOTOR HOUSING and pry it out with a screwdriver. Insert a flat-blade screwdriver into the snap bushing hole and into the slot in the end of the MOTOR SHAFT to lock the ROTOR.
6. While holding the ROTOR, unscrew the plastic IMPELLER off the MOTOR SHAFT by hand turning it clockwise (i.e., opposite to most bolts and nuts). Place the MOTOR on its back, with its SHAFT up.

7. Remove the rotary part of the mechanical SEAL by gently pulling it off the SHAFT. If too tight, use (2) small flat-blade screwdrivers. Gently pry it off the SHAFT by placing the flat side of the blades onto opposite sides of the mechanical SEAL.
8. Remove the stationary part of the SEAL by gently prying it off the steel FACEPLATE.
9. Remove any corrosion present on the stainless steel MOTOR SHAFT with a non-metallic brush or scrub pad. Do not use a wire brush or steel wool.
10. Install the new stationary part of the SEAL into the FACEPLATE: first, the rubber CUP by firmly pressing it down until it bottoms, then the ceramic DISK. The DISK face with a circular groove should be put against the rubber CUP (the visible DISK face should be smooth). Press the DISK firmly down until it, too, bottoms into the rubber CUP. The ceramic DISK should be clean. If needed, wipe it with alcohol and a soft cloth.
11. Install the new rotating part of the SEAL by gently pushing it, by hand, onto the SHAFT (graphite ring first) until its steel CAP stops on the SHAFT.
12. Check that:
 - a) The height of the steel CAP over the ceramic DISK is between 0.33" and 0.35" (8.4 mm and 8.9 mm). If it is more than 0.35" (8.9 mm), then try pushing it further down, carefully, but harder.
 - b) The graphite DISK is pressed against the ceramic DISK (by a spring inside of it).If either (a) or (b) is not happening, then contact Armstrong Technical Support: phone (416) 755-2291 or email techsupport@armlink.com.
13. "Lock" again the MOTOR ROTOR and SHAFT as per step 5 above, in order to perform the next step.
14. Fasten the plastic IMPELLER onto the SHAFT, turning it by hand counter-clockwise until it stops (when it touches the SEAL's steel CAP). Do not tighten it excessively.
15. Ensure that the GASKET is properly seated in the PUMP CASING GASKET groove. Holding the MOTOR body, insert the IMPELLER straight into the PUMP CASING. Verify that the GASKET was not dislodged during insertion, and is still seated properly. Hold the MOTOR BODY steady while fastening the (4) BOLTS that attach the MOTOR to the PUMP CASING. Tighten evenly and diagonally. There should be a small, even gap of about 0.02" (0.5 mm) all around between the MOTOR FLANGE and the PUMP CASING.
16. Reattach 1" water HOSE, and remove blockage from PUMP INLET PORT (if applicable).

Water Pump Startup

If the ICE STORAGE TANK was drained prior to WATER PUMP repairs, refill or top off the TANK with clean potable water as per the ICE BEAR UNIT's installation instructions. DO NOT attempt to start the WATER PUMP until the ICE STORAGE TANK has been completely filled with water.

NOTE: If the system is allowed to run dry, the mechanical SEAL will be damaged.

Procedure

1. Restore electrical power to ICE BEAR UNIT and initiate a forced Melt (install JUMPER between DIGITAL INPUT PIN #2 and PIN #8 in COOLDATA CONTROLLER) to check WATER PUMP operation.

NOTE: Both the REFRIGERANT PUMP and WATER PUMP will operate during a forced Melt.
2. Ensure that WATER PUMP is not leaking.
3. Remove JUMPER installed in step 1.

Water Pump Replacement Parts

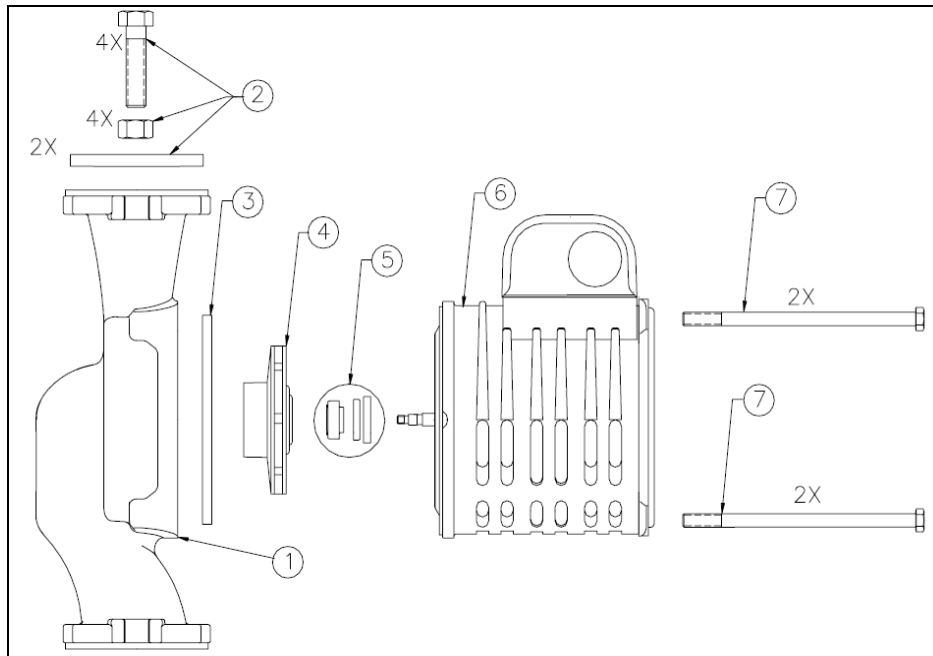

Armstrong Model	(1)	(2)	(3)	(4)	(5)	(6)		(7)
	Body – Bronze	Flange Hardware Kit	Body Gasket	Impeller	Mechanical Seal	Motor Assy 120V	Motor Assy 240V	Motor Housing Cap Screw
E9	880200-141	810120-244	880200-071	880200-030	880200-277	880200-082	880200-182	911117-236

Water Pump Replacement

1. Ensure that the ICE BEAR UNIT's electrical power is disconnected and locked out.
2. Disconnect the 1" water HOSE inside the TANK to prevent siphoning (disconnect using either HOSE CLAMP). See Figure 18.
3. In certain locations, draining of the ICE STORAGE TANK may not be feasible; therefore, simply blocking the PUMP INLET PORT inside the TANK will prevent water from draining while servicing. See Figure 18 for location of PUMP INLET PORT.
4. Loosen the SCREW from the TERMINAL BOX COVER, and remove the SCREW and COVER.
5. Disconnect the supply WIRES only to the WATER PUMP, leaving the CAPACITOR WIRES connected.
6. To relieve any residual pressure that may be present in the PUMP body, loosen the flange BOLTS and gently move the PUMP body back and forth a bit to allow the water to escape.
7. If the TANK is not drained, verify that PUMP INLET PORT is securely blocked before proceeding to the next step.
8. Remove the flange BOLTS and NUTS, and then remove the PUMP from the piping.
9. Inspect flange GASKETS and replace as necessary prior to reassembly.
10. Install replacement WATER PUMP.
11. Reverse assemble using steps 5 through 1 above.

Refrigerant Pump and Inverter Service

Refrigerant Pump Maintenance

- REFRIGERANT PUMP MOTOR: MOTOR is permanently lubricated and does not require annual service.
- REFRIGERANT PUMP O-RING SEALS: Perform annual refrigerant leak check to ensure O-RING SEAL integrity.

Refrigerant Pump Replacement

1. Ensure that ICE BEAR UNIT electrical power is disconnected and locked out.
2. Isolate REFRIGERANT PUMP by closing off REFRIGERANT PUMP inlet VALVE and ICE-COIL supply line VALVE. See Figure 14.
3. Recover refrigerant (approximately 4 to 8 ounces) from isolated REFRIGERANT PUMP circuit using the SERVICE PORT hidden behind the SOLENOID VALVE in Figure 14 (prior to PUMP INLET).
4. Remove REFRIGERANT PUMP / INVERTER top and side COVERS (see Figure 19).

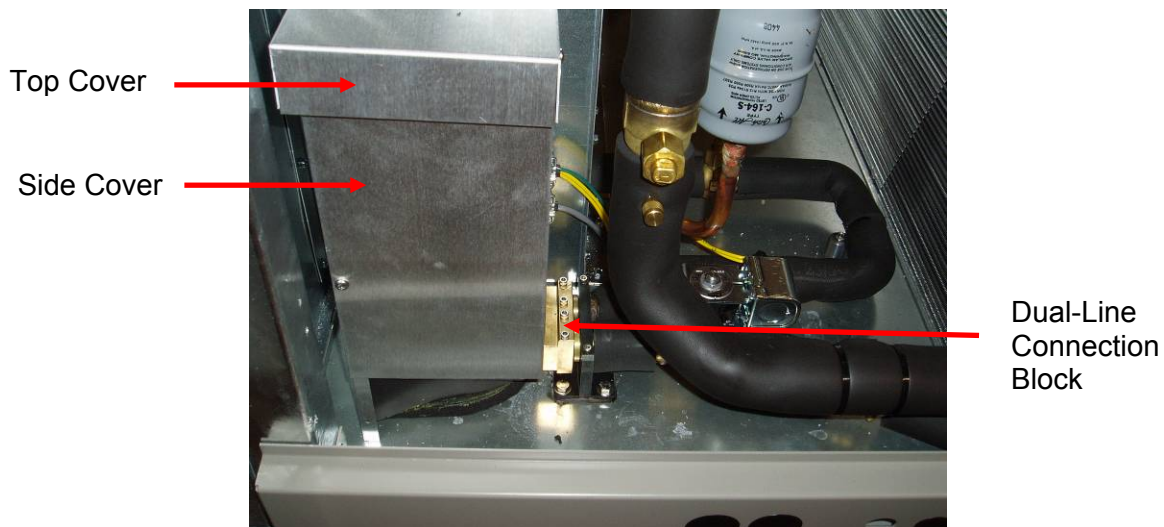

Figure 19 – Refrigerant Pump/Inverter Top & Side Covers

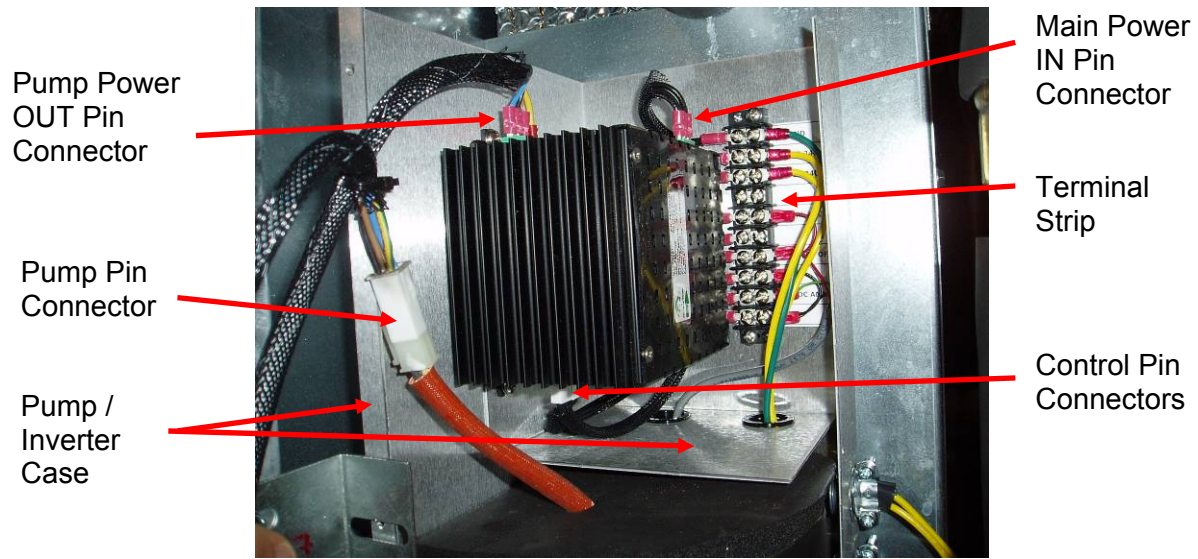

Figure 20 – Refrigerant Pump Inverter

5. Remove PUMP POWER OUT, MAIN POWER IN, CONTROL, and PUMP PIN CONNECTORS (see 20). Mark WIRES for re-assembly.

NOTE: Observe orientation of PIN CONNECTORS. PIN CONNECTORS can be installed backwards, which will cause INVERTER failure.

6. Unbolt (4) 7/16 x 1/4" NUTS from PUMP to PUMP/INVERTER CASE (reference Figure 21).
7. Remove (4) 9/64" hex stainless SCREWS from brass DUAL-LINE CONNECTION BLOCK (refer to Figure 21).
8. Carefully ease REFRIGERANT PUMP and HOUSING off to the left of the DUAL-LINE CONNECTION BLOCK (refer to Figure 21).

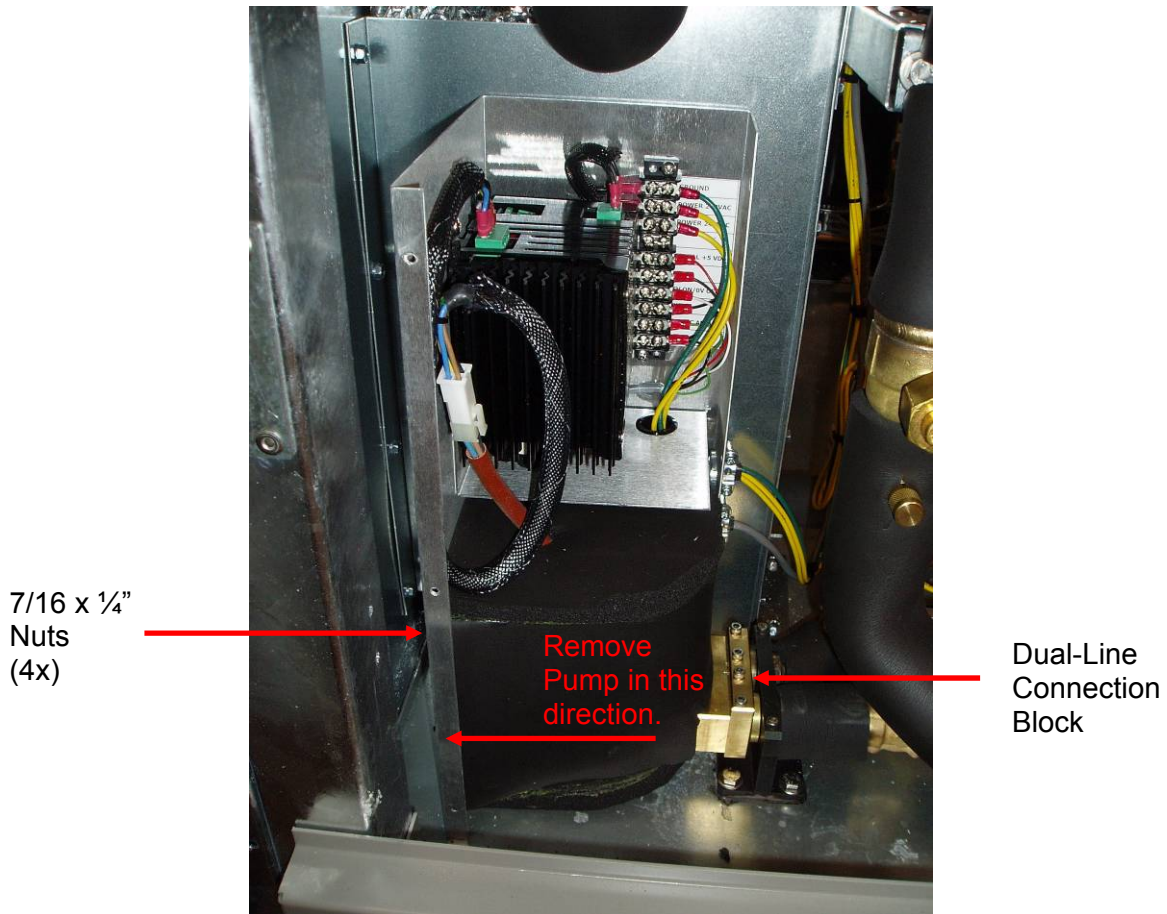

Figure 21 – Refrigerant Pump & Inverter Assembly

Refrigerant Pump Replacement

1. Remove SHIPPING PLUGS from replacement PUMP PORTS.
2. Install and lubricate O-RINGS on male brass PUMP FITTINGS (using Parker Super O-Ring Lube).
3. Reverse assemble PUMP using steps 8 through 4 above.
4. Evacuate isolated PUMP circuit to 1200 to 900 microns.

CAUTION: Evacuating below 900 microns could damage O-RINGS.

5. Open REFRIGERANT PUMP inlet VALVE and check for refrigerant leaks.
6. Weigh in refrigerant charge removed in step #3 of *Refrigerant Pump Replacement* section above.
7. Open ICE-COIL supply line VALVE.
8. Restore ICE BEAR UNIT electrical power and initiate a forced Melt (install JUMPER between DIGITAL INPUT PIN #2 and PIN #8 in COOLDATA CONTROLLER) to check REFRIGERANT PUMP operation.
9. Install all removed Schrader CAPS, remove JUMPER in COOLDATA CONTROLLER, and secure all COVERS and DOORS.

Refrigerant Pump Inverter Replacement

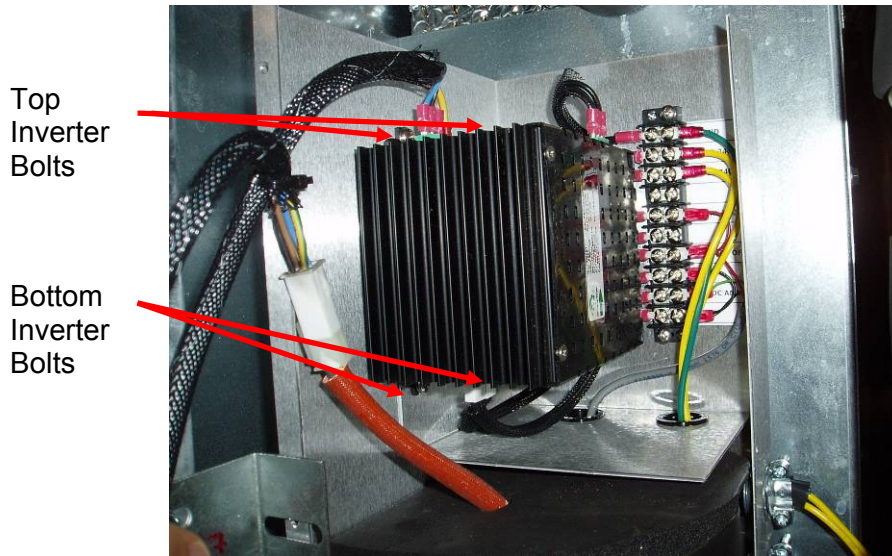

Figure 22 – Inverter Bolts

1. Ensure that ICE BEAR UNIT electrical power is disconnected and locked out.
2. Remove REFRIGERANT PUMP/INVERTER top and side COVERS.
3. Remove PUMP POWER OUT, MAIN POWER IN, CONTROL, and PUMP PIN CONNECTORS (see 20). Mark WIRES for re-assembly.

NOTE: Observe orientation of PIN CONNECTORS. PIN CONNECTORS can be installed backwards, which will cause INVERTER failure.

4. Remove the top (2) Phillips-head BOLTS on the top section of the INVERTER (see Figure 22).
5. Loosen the bottom (2) Phillips-head BOLTS on the bottom section of the INVERTER (see Figure 22).
6. Remove INVERTER.

New Inverter Installation

1. Reverse assemble using steps 5 through 2 above.
2. Restore ICE BEAR UNIT electrical power and initiate forced Melt (install JUMPER between DIGITAL INPUT PIN #2 and PIN #8 in COOLDATA CONTROLLER) to check REFRIGERANT PUMP operation.
3. Remove JUMPER in COOLDATA CONTROLLER, and secure all COVERS and DOORS.

Ice Energy, Inc.
9351 Eastman Park Dr., Suite B
Windsor, CO 80550
Phone: 877-5-ICEBEAR (877-542-3232)
(970) 545-3630
Fax: (970) 545-3634
www.ice-energy.com

For parts or service, contact your Ice Energy representative.
